

EVOLUTION[™]

STEEL DECK FRAMING

TABLE OF CONTENTS

Introduction

General Guidelines.....	3
Required Tools/Components.....	4

Installation

Installation Overview.....	6
Project Planning.....	8
Cutting & Painting.....	11
Framing Connections	
S-Ledger To Structure.....	13
Post Onto Concrete Footing.....	15
Bury Post Into Footing.....	17
Post To Single Beam.....	18
Post To Double Beam.....	20
End Joists To S-Ledger & Beam.....	22
Joists To S-Ledger & Beam.....	24
End Joist To Beam & S-Ledger (Flush Mount).....	25
Joist To Beam & S-Ledger (Flush Mount).....	26
Evolution Strap To Joist.....	27
Non-Standard Spacing at Mid-Span & General Blocking.....	29
Pre-Punched U-Rim Joist To Joists.....	29
Blank U-Rim Joist To Joists.....	30
Curved U-Rim Joist To Joists.....	31
Joist As Rim Joist.....	33
Joist & Beam Cap.....	35
Beam Splice Over Post.....	35
Tile Tray.....	39
E15 and E22 Mid-Post Bracket.....	44
HUCQ Bracket.....	47
24in. Lateral Bracing.....	48

Care & Maintenance/Span Charts.....	49
-------------------------------------	----

Post To Frame Connections/Frame Inspection

Checklist/Warranty.....	50
-------------------------	----

INTRODUCTION

READ INSTRUCTIONS COMPLETELY BEFORE STARTING INSTALLATION

General Guidelines

It is the responsibility of the installer to meet all code and safety requirements, and to obtain all required building permits. The framing installer should determine and implement appropriate installation techniques for each installation situation. Fortress Building Products nor its distributors shall **NOT** be held liable for improper or unsafe installations.

Reference <https://bpdirectory.intertek.com/> for span charts. Search for CCRR #0313. It is critical to **NOT** exceed defined allowable maximum spans.

Personal Protection Equipment (PPE) must be worn anytime you're using power tools and working with Evolution framing. Eye protection, hearing protection, closed-toe shoes, gloves, long sleeves, and pants must be worn to keep yourself safe.

The installer holds primary responsibility for implementing all necessary safety measures.

As the steel framing parts are cut, all metal shavings and/or chips must be removed from inside the Evolution Framing parts. At the end of a work period, all steel shavings and/or chips must be cleaned off the jobsite. Not doing so could result in the staining of surrounding surfaces.

As the steel framing parts are cut, **DO NOT** allow metal shavings and/or chips to get dropped or blown into a pool, hot tub, or any other body of water. Staining could occur if this were to happen.

Fortress Building Products **DOES NOT** cover all possible installation scenarios within these instructions. In some cases, it may be necessary for you to consult a professional engineer, building code official, or local dealer. In addition, it may become necessary to use brackets other than Fortress' when more complex installations take place.

Required Tools



Components

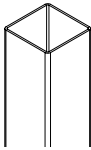

Post

3-1/2" x 3-1/2" x 10',
5-1/2" x 5-1/2" x 20'
[89mm x 89mm x 3048mm,
140mm x 140mm x 6096mm]

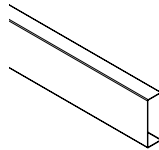

Joist

2" x 6" x 12',
14', 16', 18', 20'
[51mm x 152mm x 3658mm,
4267mm, 4877mm, 5486mm,
6096mm]

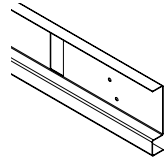

S-Ledger

2" x 8" x 8',
12', 20'
[51mm x 203mm x 2438mm,
3658mm, 6096mm]

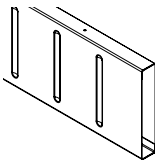

Beam

2" x 11" x 8',
12', 16', 20'
[51mm x 279mm x 2438mm,
3658mm, 4877mm, 6096mm]

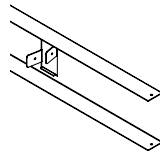

**U-Rim Joist
(Pre-Punched & Blank)**

2" x 6" x 8'
[51mm x 152mm x 2438mm]

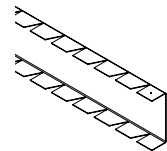

**U-Rim Joist
(Curved)**

2" x 6" x 8'
[51mm x 152mm x 2438mm]

The dimensions shown of components are rounded and **NOT** actual size.

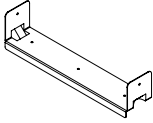

Beam Blocking

(12" OC or 16" OC)

2" x 2-1/2" x 10", 14"

[51mm x 64mm x 254mm, 356mm]

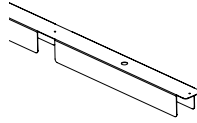

Evolution Strap

(12" OC or 16" OC)

2" x 2" x 48"

[51mm x 51mm x 1219mm]

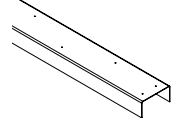

Double Beam Track

2" x 4" x 48"

[51mm x 102mm x 1219mm]



Concrete Anchor

3/8" x 3" [10mm x 76mm]

(NOT PROVIDED BY FORTRESS)



Evolution Self-drilling Screw

3/4" [19mm] #12



Joist/Beam Cap

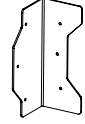

F-50 Bracket

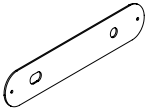

8in. Strap

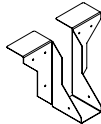

Single Hanger Bracket

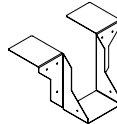

Double Hanger Bracket

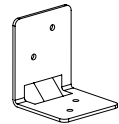

F-10 Bracket

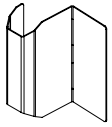

Rim Joist Bracket

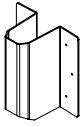

Ledger Bracket

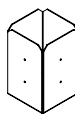

Post to Pier Bracket

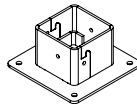

HUCQ 2.25" Bracket

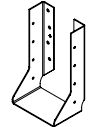

HUCQ 4.5" Bracket

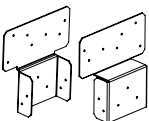

Single Beam To 3.5" Post Bracket

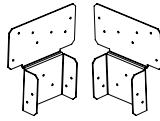

Double Beam To 3.5" Post Bracket



3.5" Beam Splice Post Cap

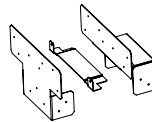

Single Beam To 5.5" Post Bracket

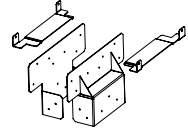

Double Beam To 5.5" Post Bracket

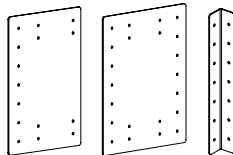

E-15 and E-22 and Supporting L Bracket

The dimensions shown of components are rounded and **NOT** actual size.

INSTALLATION OVERVIEW

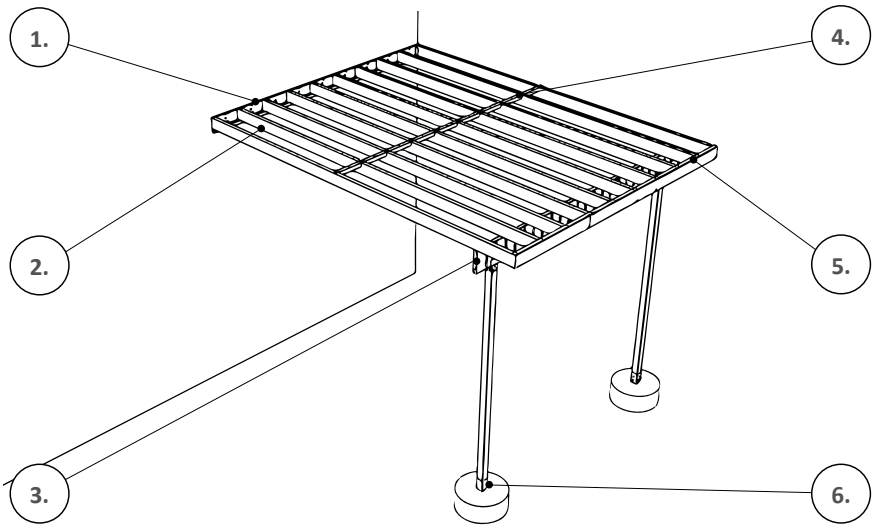

Evolution Framing Connections

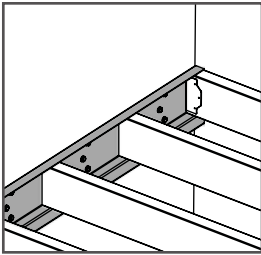

1.
S-Ledger To Structure

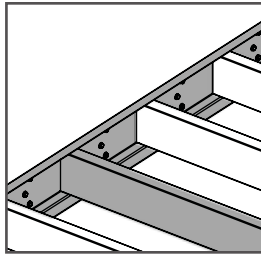

2.
S-Ledger To Joist

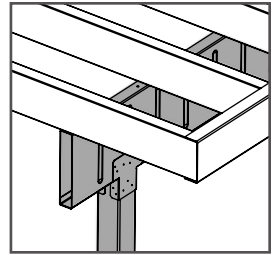

3.
Post To Beam

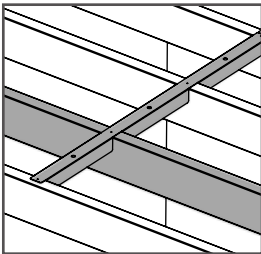

4.
Joist To Evolution Strap

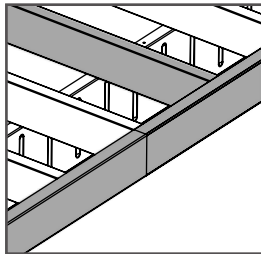

5.
Joist to U-Rim Joist

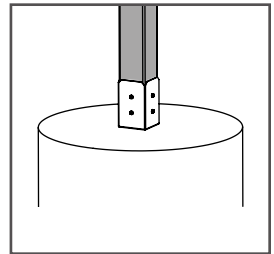

6.
Post to Footing

Note:

Construction methodologies are always improving. Please visit FortressBP.com for the most up-to-date Installation Instructions.

Evolution Framing Installation Process (Overview)

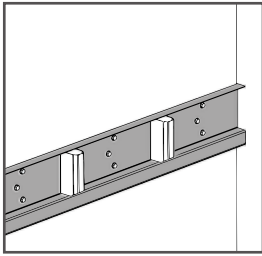

1.
Mount S-Ledger
Onto Structure

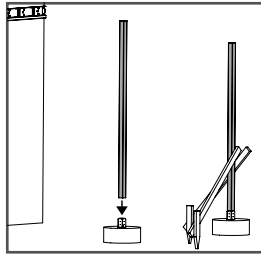

2.
Mount Posts To
Footing and Brace

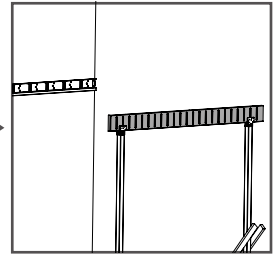

3.
Install Beam
(Single or Double Beam)

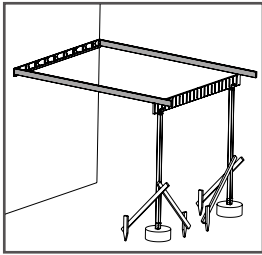

4.
Install End Joists

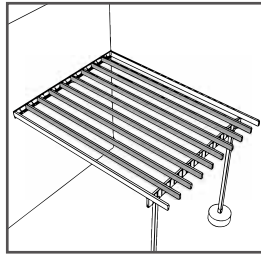

5.
Install Joists

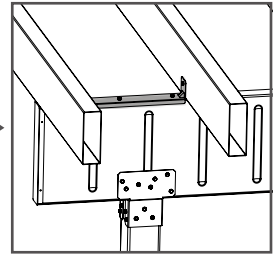

6.
Install Beam Blocking

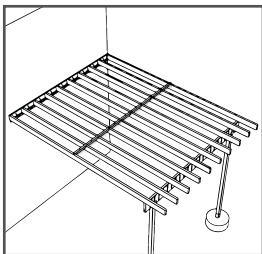

7.
Install Evolution Strap

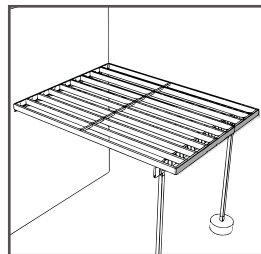

8.
Install U-Rim Joist
(Pre-Punched, Blank,
Curved or Joist as U-Rim)

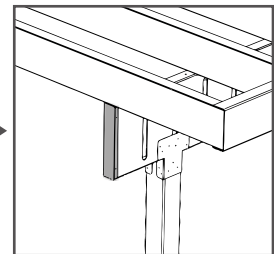

9.
Install Joist or
Beam Caps

Note:

Construction methodologies are always improving. Please visit FortressBP.com for the most up-to-date Installation Instructions.

PROJECT PLANNING

Step 1: Sketch Layout of Framing Project

1. Sketch the top and side of the house/building profile.
2. Identify the desired location of your framing project.
3. Using a tape measure determine the required length, width and height of the framing project.
4. Determine desired post locations and post height.
5. Determine required spacing between joists (on center or non-standard).
6. Determine number of joists required.
7. Mark critical dimensions onto the previously sketched top and side views of house/building for future reference.

Note:

- **Standard spacing between joists:** 12" [305mm] on center or 16" [406mm] on center.
- Reference <https://bpdirectory.intertek.com/> for span charts. Search for CCRR #0313. It is critical to **NOT** exceed defined allowable maximum spans.

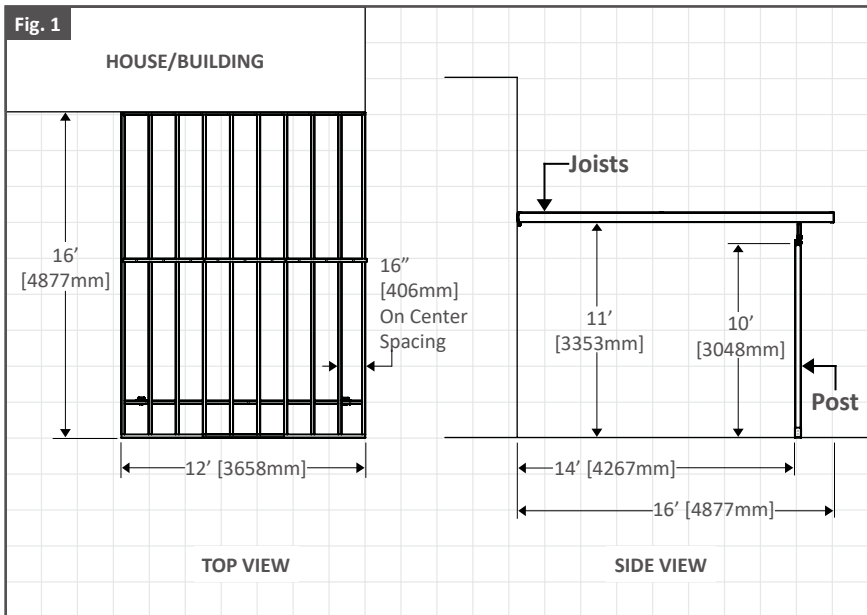

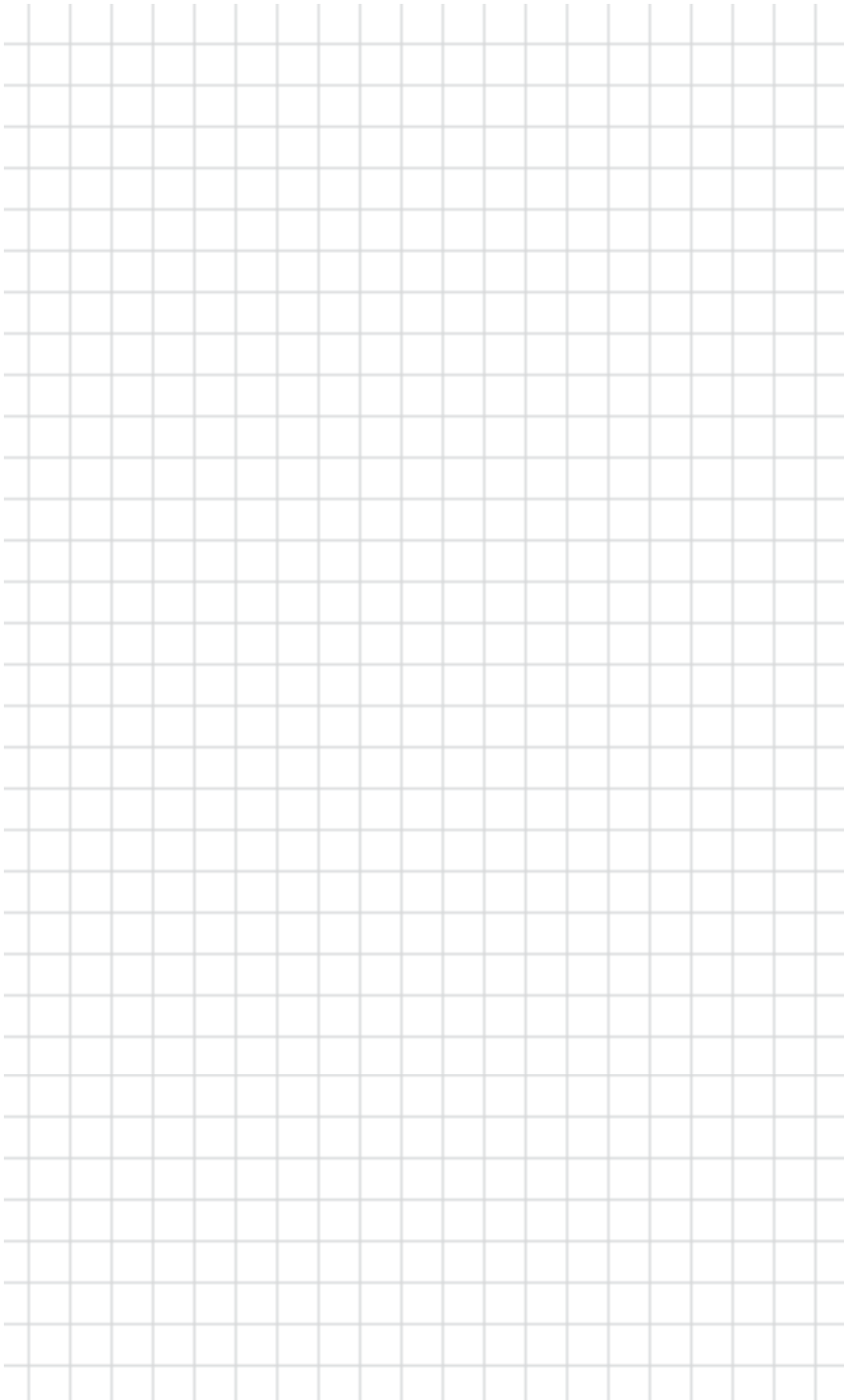

Step 2: Create a Perimeter For The Framing Project

1. Using Stakes and Guide String, create a perimeter for the framing project. As shown in Fig. 2.

Tip:

- Be sure corners are set at 90° angles.

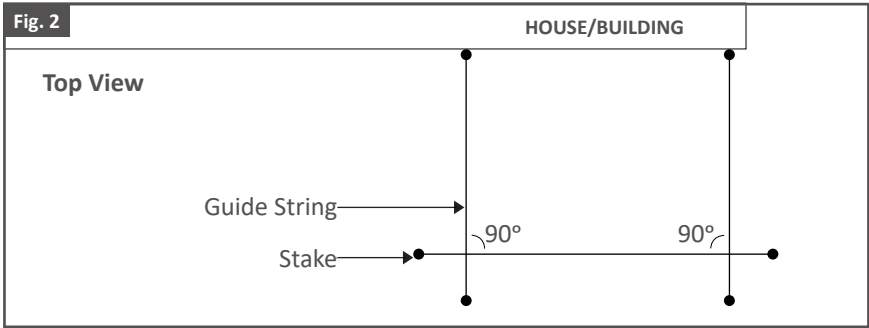

Step 3: Mark & Dig Footing Hole Locations

1. Using spray paint, mark the center of the desired footing hole locations. As shown in Fig. 3.
2. Consult local code requirements for exact footing hole width and depth requirements. As shown in Fig. 4.
3. Dig the footing holes using a Post Hole Digger.
4. Be sure to keep the Post Hole Digger straight and plumb when digging.
5. **DO NOT POUR CONCRETE IN THIS STEP.**

Note:

- Call 811 before you dig the footing holes to locate and identify any buried utilities.

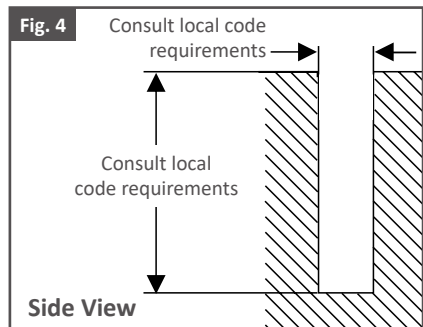
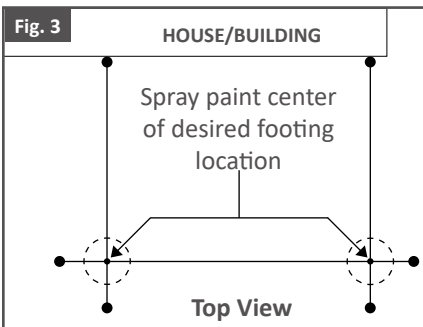

CUTTING & PAINTING

Step 1: Mark Cut Points

1. Position the material to be cut on a flat surface, preferably Saw Horses.
2. Using a pencil, mark desired cut length onto material.
3. Using a speed square, straighten cut point markings on top and side faces. As shown in Fig. 5.

Tip:

- Before making cuts, confirm cut length is correct.

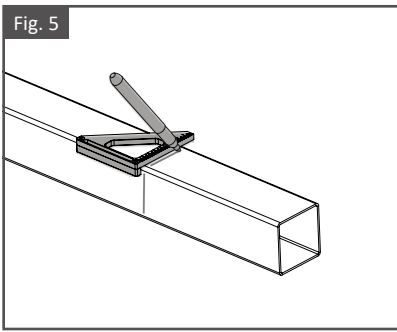

Step 2: Cut Material To Length

1. Cut the material using a metal cutting circular saw or grinder with a cutoff disc. As shown in Fig. 6. Be sure to follow cut marks on top and side faces.

Tip:

- **Be sure to use a saw and blade designed to cut metal. Metal cutting saws rotate a lower RPM. Using a standard wood saw will lead to premature wearing of the blade.**
- Be sure to support product to prevent bending during cutting.
- Be sure to not over heat the material when making cuts with a grinder.

Fig. 6

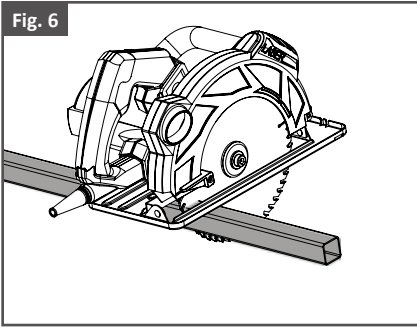

Step 3: Clean Cut Areas

1. Use a file to smooth cut edges. As shown in Fig. 7.
2. Remove any metal shavings and dust with a brush or rag.
3. Make sure surfaces to be painted are clean. **DO NOT** cut product over concrete. Be sure to remove any metal shavings to avoid stains.

Tip:

- **DO NOT** allow metal shavings and/or chips to get dropped or blown into a pool, hot tub, or any other body of water.
- **Be sure to remove metal shavings and/or chips from inside the cut material. Not doing so may result in rust and staining of ground surfaces after installation.**

Fig. 7

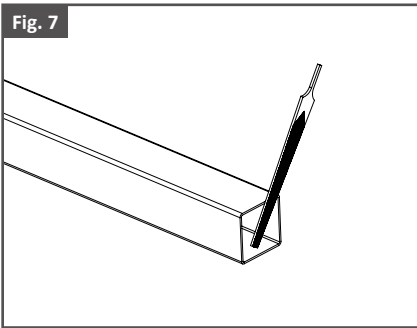

Step 4: Apply Spray Paint To Cut Areas

1. Using a piece of cardboard as a mask, apply the 1st coat of Fortress zinc based touch-up paint.
2. Allow to dry before applying second coat.
3. Apply the 2nd coat of Fortress zinc based touch-up paint.
4. Allow to dry and install.

Tip:

- Apply 2 coats of spray paint in non-salt water environments and 3 coats in salt-water environments.

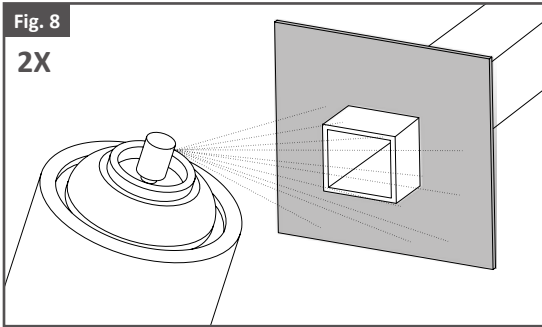

FRAMING CONNECTIONS

Connection 1: S-Ledger To Structure

1. Insert Ledger Brackets into S-Ledger openings. As shown in Fig. 9. Ledger Brackets are press fit into place.
2. Be sure angle cut edge in Ledger Bracket is facing down once installed. As shown in Fig. 10. Adjust if needed.
3. Place S-Ledger in desired position onto structure.
4. Mark screw hole locations onto structure. As shown in Fig. 11.
5. Using a 3/8" [10mm] bit, Pre-drill screw holes into structure. Attachment to the structure will vary depending on the attachment material and geographical region. Consult your local building code official or structural engineer to determine the proper size and type of bolt/screw to use to attach the S-ledger to the structure.
6. Position S-Ledger over pre-drilled holes then, using 3/8" [10mm] bolt and washers, fasten S-Ledger to structure. As shown in Fig. 12. **All pre-drilled holes should be used when securing the S-Ledger to the structure.**
7. Attach F-50 Brackets to the outside edges of the S-Ledger with Evolution Self-Drilling Screws. As shown in Fig. 13. The notched side of the F-50 Bracket is designed to line up flush with the edge of the S-Ledger.

Note:

- The F-50 Bracket is also used anytime there's a joist attachment to the S-Ledger that requires non-standard spacing. This could occur if you're adding joists for blocking or adding additional support.
- If local building code requires connectors larger than 3/8" [10mm], the factory sized holes can be drilled out using a metal cutting drill bit.
- Flashing/Water Management requirements will vary from region to region. Consult your local building code official or structural engineer for proper flashing/water management treatment.

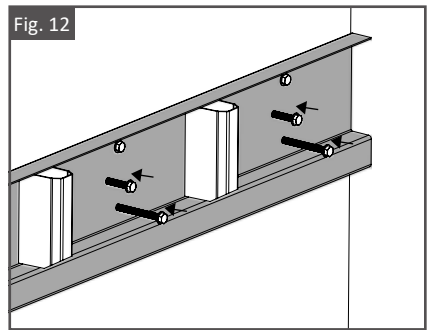
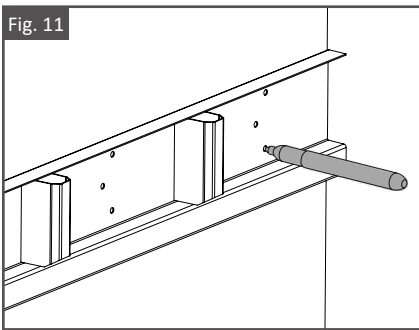
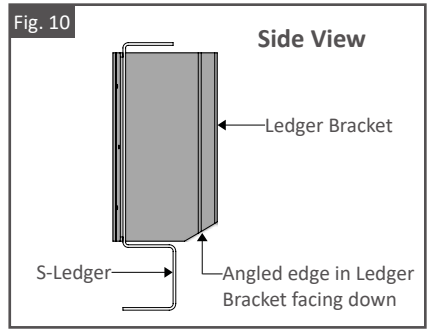
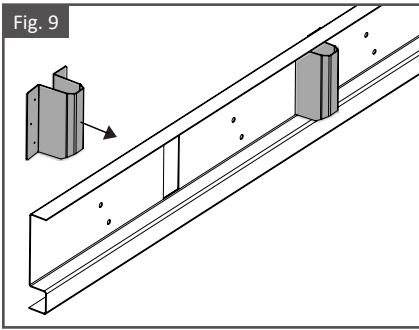
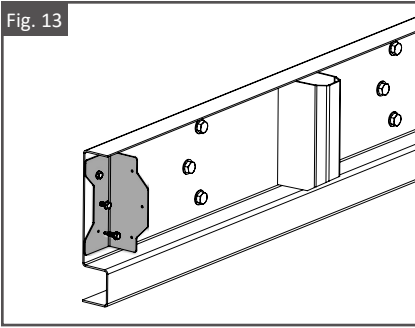

Fig. 13



Connection 2: Post Onto Concrete Footing

1. Fill footing holes (Page 10, step 3) with concrete. The concrete can be **at least 1" [25mm]** above the ground surface.
2. Be sure top surface of concrete is level once fully cured.
3. Cut posts to desired height. Reference cutting and painting instructions on pages 11 - 13.
4. Pre-drill concrete footing, then mount Post to Pier Brackets onto surface using 3/8" x 3" [10mm x 76mm] Concrete Anchors. As shown in Fig. 14 & 15. Use the string (page 10, step 2) as a guide when positioning the Post To Pier Brackets.
5. Using Evolution Self-Drilling Screws, fasten Beam to Post Brackets (Single Beam or Double Beam) onto top edge of post. As shown in Fig. 16 & 17.
6. Insert Posts into Post to Pier Brackets. As shown in Fig. 18. Be sure to have Beam to Post Brackets orientated in desired direction to allow for the Beam to be mounted correctly.
7. Confirm that the post is level and plumb.
8. Fasten Posts onto Post to Pier Brackets using Evolution Self-Drilling Screws. As shown in Fig. 19. Continuously check if post is level and plumb.

Note:

- Allow the concrete to cure for a minimum of 24 hours before installing Posts.
- Post installation requirements will vary in different geographical regions. Consult with your local building code officials for requirements.

- When not mounting posts onto a footing, Fortress recommends the use of Helical Piers. The use of specialized equipment is required for Helical Pier installation, be sure to contact a building professional.
- **It is critical for posts and post brackets to maintain the 90° angles established in project planning instructions steps 2 & 3, on page 10.**
- **It is critical for post heights to be relatively even/coplanar once installed. This will help ensure the frame assembly is level once installed.**

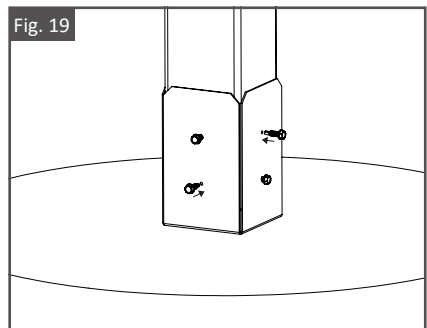
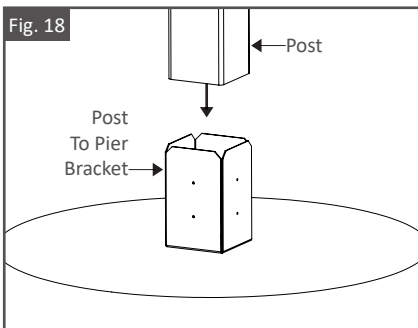
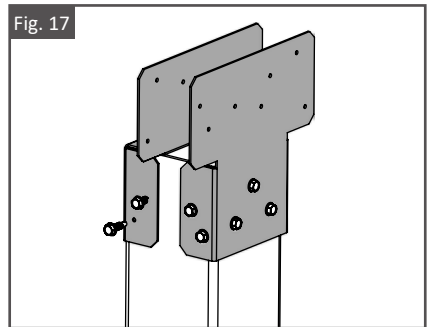
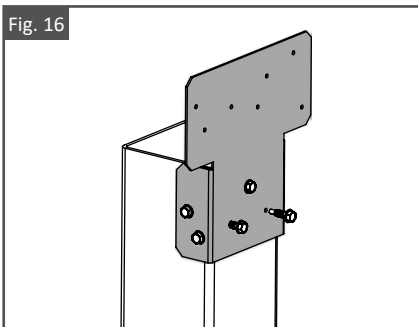
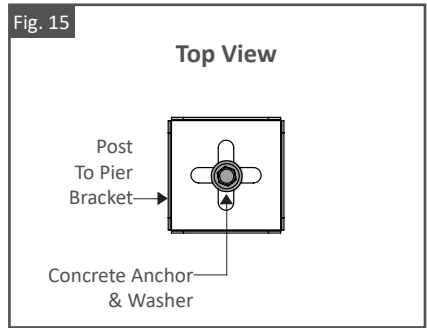
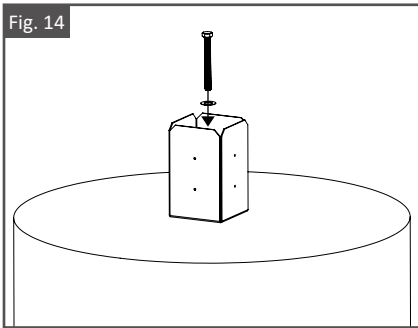

Connection 3: Bury Post Into Footing (Alternative to Connection 2)

1. Fill footing holes with 3" [76mm] of gravel or crushed stone to allow for drainage. As shown in Fig. 20.
2. Compact the gravel before setting the Posts.
3. Use tape measure to check depth. Evolution Posts are designed to be buried at a **minimum** of 36" [914mm] depth. As shown in Fig. 21.
4. Use the string (page 10, step 2) as a guide when positioning a Post into each hole. As shown in Fig. 22.
5. With Posts set, Fill Footings holes with concrete to 1" [25mm] above ground surface. As shown in Fig. 23.
6. Use a level to confirm that Posts are plumb and aligned with the Guide Strings. Adjust if needed.

Tip:

- Be sure to account for slopes in ground surface when setting Posts.
- Allow concrete to cure for a minimum of 24 hours before installing brackets.
- As the concrete cures, be sure to keep posts placed along guide strings & continuously check that they are plumb as well as in line with the next post.

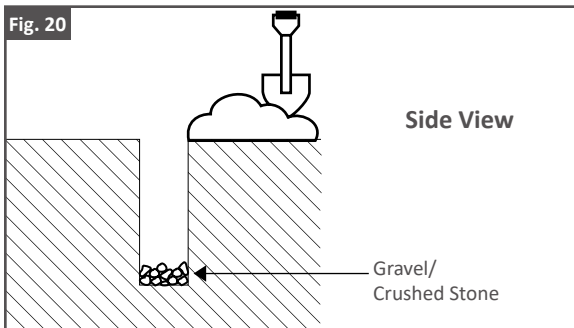

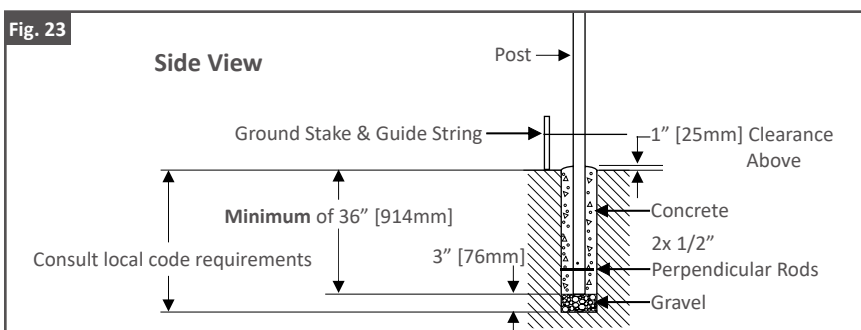
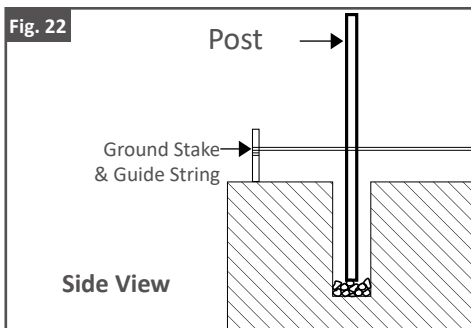
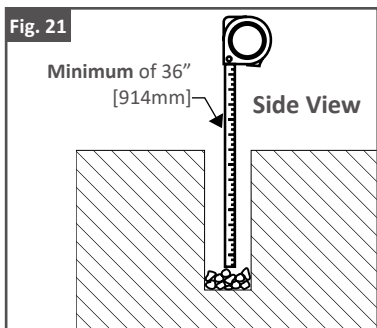

Connection 4A: Post To Single Beam

1. Position Beam into desired position. As shown in Fig. 24.
2. Confirm both ends of the Beam and S-Ledger are in Line. As shown in Fig. 25. Adjust if needed.
3. All Beams contain holes to allow for water drainage. Be sure drainage holes on Beam face down once installed. As shown in Fig. 26. Adjust if needed.
4. While keeping the Beam in position, use Evolution Self-Drilling Screws to fasten brackets onto the Beam. As shown in Fig. 27. The use of Clamps is recommended to keep Beam in desired position.

Note:

- The **maximum** Beam to Post overhang allowed is 24" [610mm]. As shown in Fig. 28.

Fig. 24

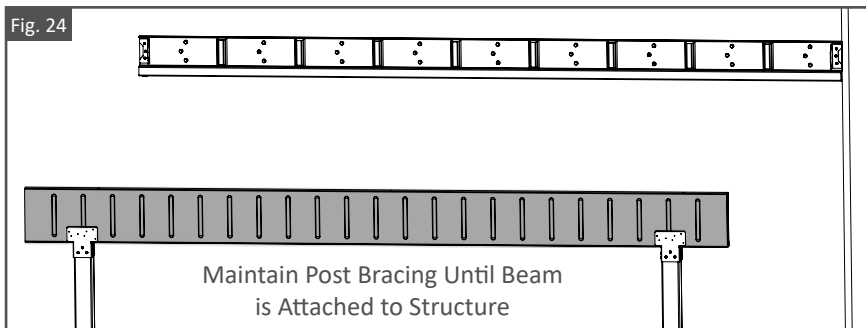

Fig. 25

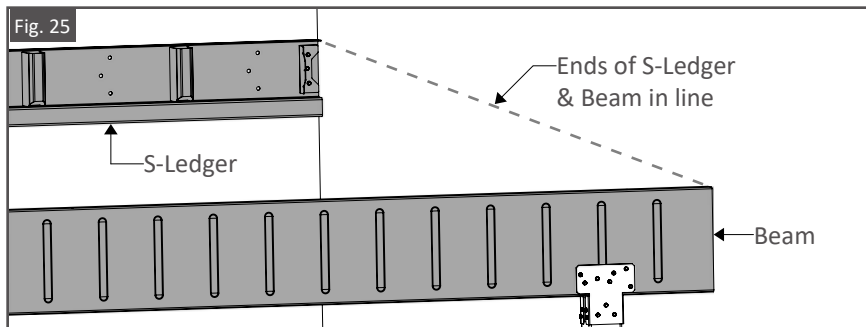

Fig. 26

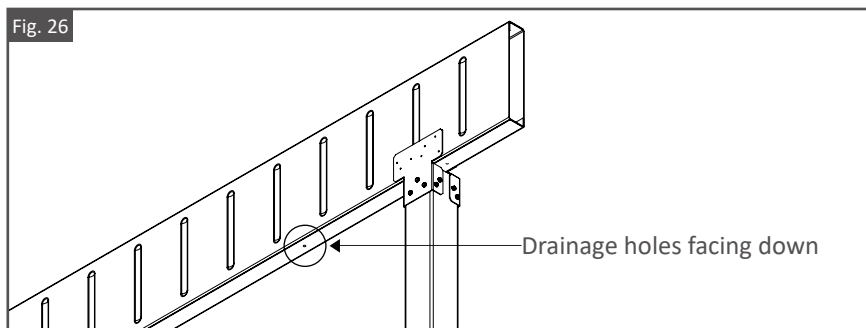

Fig. 27

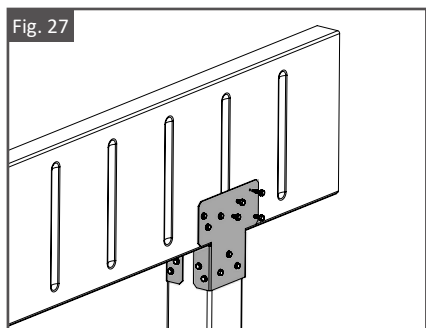
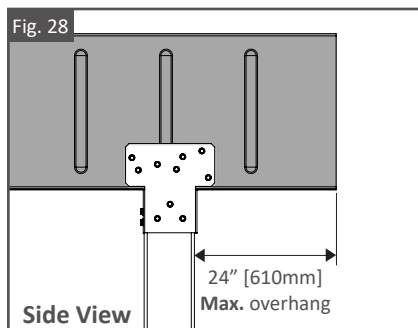

Fig. 28



Connection 4B: Post To Double Beam (Alternative To Connection 4A)

1. Using the Double Beam Track, couple two Beams together to create a Double Beam. As shown in Fig. 29. The Double Beam Track must be installed continuously across the length of the Double Beam and on both top and bottom faces of beam.
2. Fasten Double Beam Track to Double Beam using Evolution Self-drilling Screws. As shown in Fig. 30. Be sure to have ends of Double Beam flush before fastening.
3. Mount Double Beam in desired position onto Post and in between two Double Beam to Post Brackets.
4. Using Evolution Self-drilling Screws, fasten Double Beam to Post Brackets onto Double Beam. As shown in Fig. 31. Be sure Beam is parallel to and ends are in line with S-Ledger.

Note:

- The Double Beam Tracks are packaged in pairs and come in 4' [1219mm] sections.
- The **maximum** Double Beam to post overhang allowed is 24" [610mm]. As shown in Fig. 32.
- **BEAM SPLICING:** When splicing two beams, there must be a **minimum** of 24" [610mm] of overlap between the two beams. As shown in Fig. 33 & 34. The splice must be supported by a post at any location within the beam overlap. The beam splice is connected with (4) 3/8" [10mm] diameter thru bolts, nuts, and washers. As shown in Fig. 35 & 36.
- All Beams contain holes to allow for water drainage. Be sure drainage holes on Beam face down once installed. Reference Fig. 26 on page 19. Adjust if needed.

Fig. 29

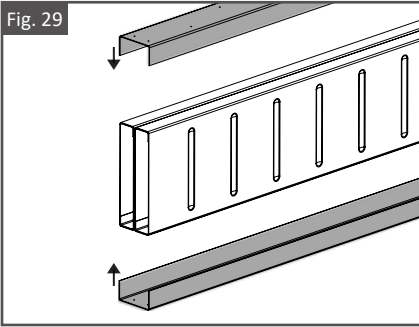

Fig. 30

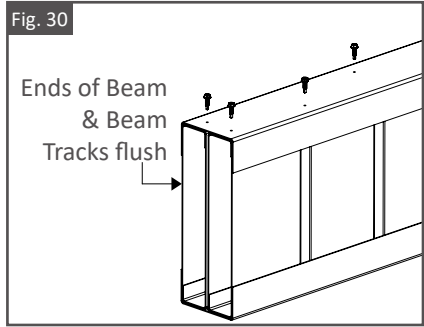

Fig. 31

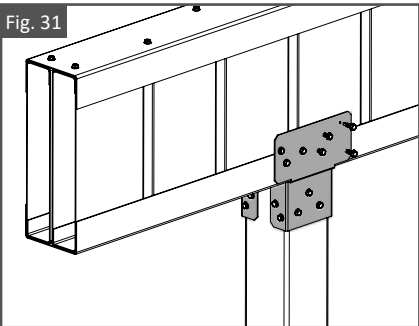

Fig. 32

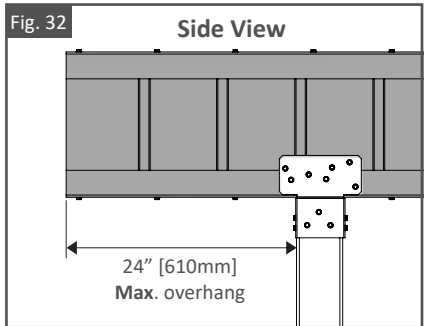

Fig. 33

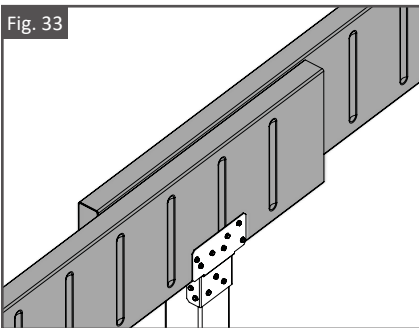

Fig. 34

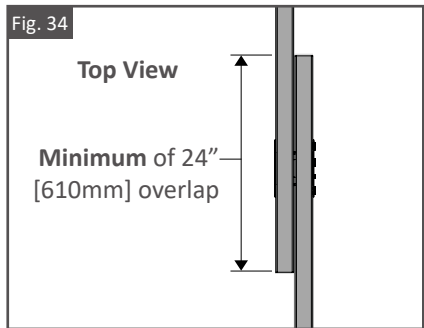

Fig. 35

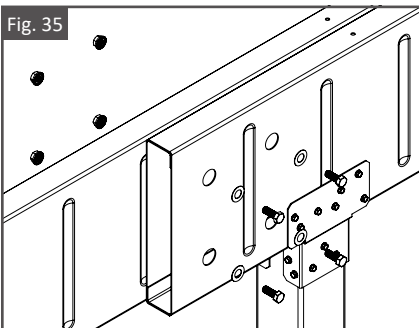
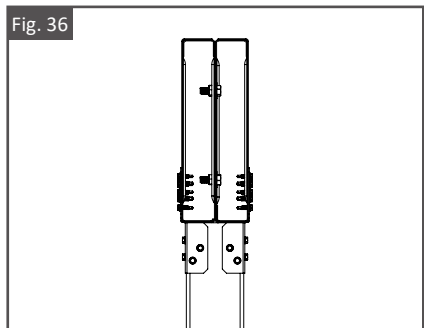

Fig. 36



Connection 5A: End Joists To S-Ledger & Beam

1. If required, cut joists to desired length. Reference cutting and painting instructions on pages 11 - 13.
2. Mount End Joists flush onto both ends of the S-Ledger. As shown in Fig. 37.
3. Using Evolution Self-drilling Screws, fasten End Joists onto F-50 Brackets. As shown in Fig. 38.
4. Confirm the End Joists and Beam are square. Adjust if needed.
5. If using standard spacing between joists, use either 12" [305mm] O.C. or 16" [406mm] O.C. Beam Blocking to mount joists onto Beam. As shown in Fig. 39.
6. If using non-standard spacing between joists, Use F-10 Brackets to mount joists onto Beam. As shown in Fig. 40.

Note:

- On both ends of the S-Ledger, and anywhere there is non-standard spacing, the F-50 Bracket is used to attach the joist in place of the Ledger Bracket.
- All joists contain holes to allow for water drainage. **Be sure drainage holes on joists face down once installed.** As shown in Fig. 41.
- **How To Square Frame:** Fortress recommends using the 3-4-5 rule. Measure and mark 3' [914mm] from the edge of Beam, measure and mark 4' [1219mm] from outer beam edge along joist, then measure between two markings. Adjust until measurement between markings is exactly 5' [1524mm]. As shown in Fig. 42. Larger triangles, with sides of 6-8-10 and 9-12-15, allow for even more accurate results.

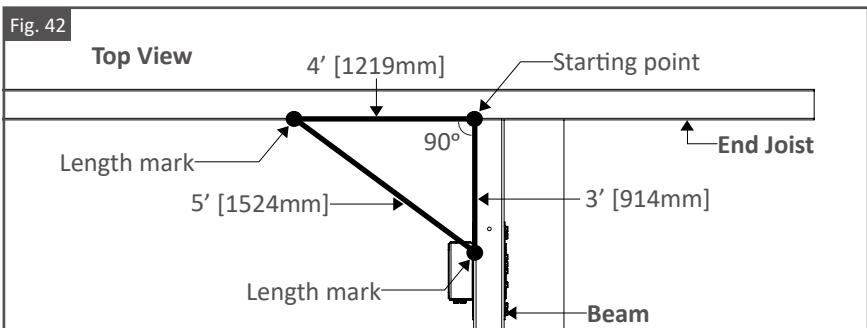
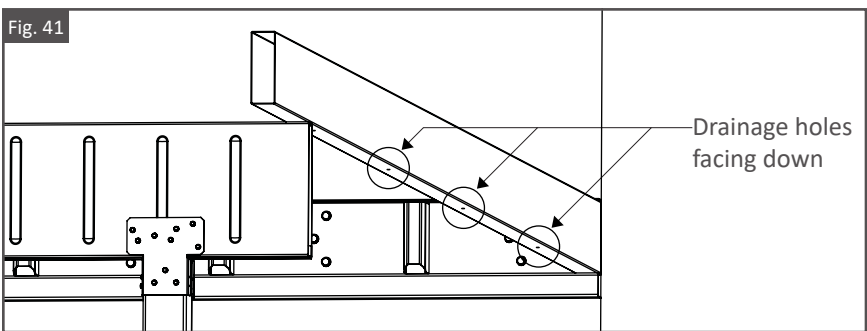
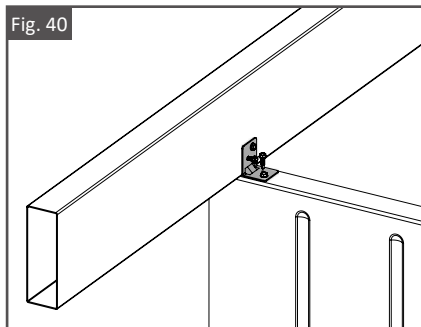
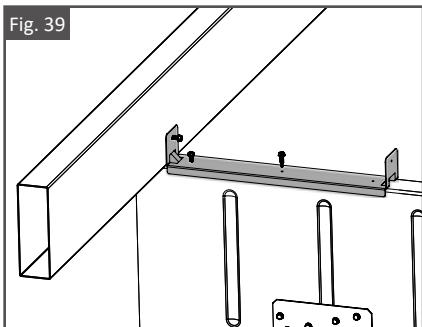
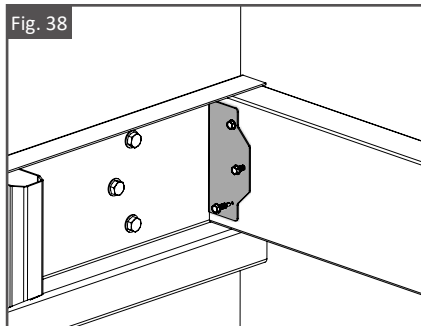
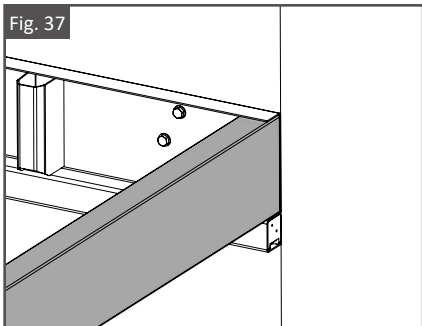

Connection 5B: Joists To S-Ledger & Beam Continued

1. Slide Joists onto the Ledger Brackets. As shown in Fig. 43. Use a 3-4 lb. Hammer and a block of wood to fully seat joists into Ledger Brackets & S-Ledger.
2. Using Evolution Self-drilling Screws, fasten Joists onto Ledger Brackets. As shown in Fig. 44. It is required to apply a screw onto each sides of a joist.
3. Determine on center spacing between joists.
4. If using standard spacing between joists, use either 12" [305mm] O.C. or 16" [406mm] O.C. Beam Blocking to mount joists onto Beam. As shown in Fig. 45.
5. If using non-standard spacing between joists, Use F-10 Brackets to mount joists onto Beam. As shown in Fig. 46.

Note:

- **Standard spacing between joists:** 12" [305mm] on center or 16" [406mm] on center.
- Blocking is required between each joist throughout the entire length of a drop beam.
- On both ends of the S-Ledger, and anywhere there is non-standard spacing, the F-50 Bracket is used to attach the joist in place of the Ledger Bracket.
- All joists contain holes to allow for water drainage. **Be sure drainage holes on joists face down once installed.** As shown in Fig. 47.

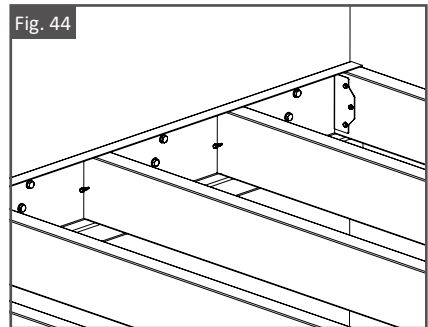
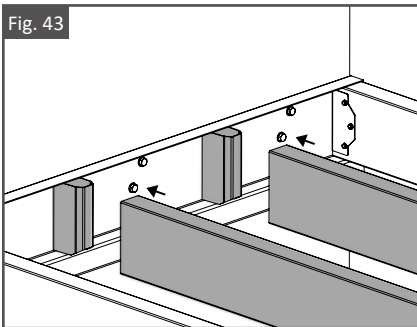

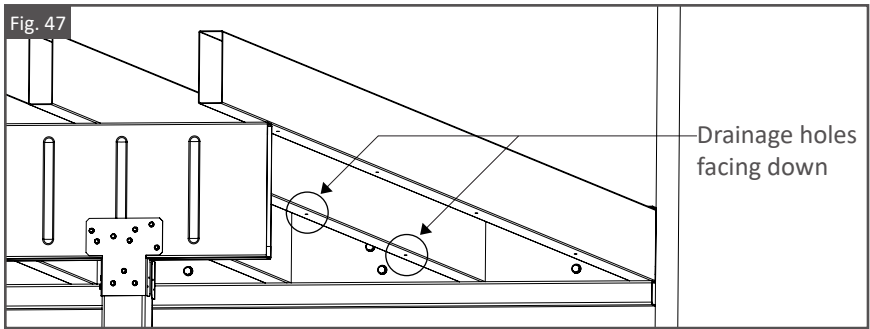
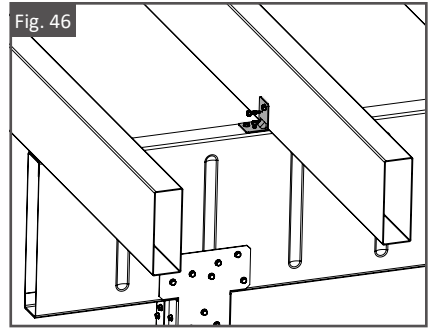
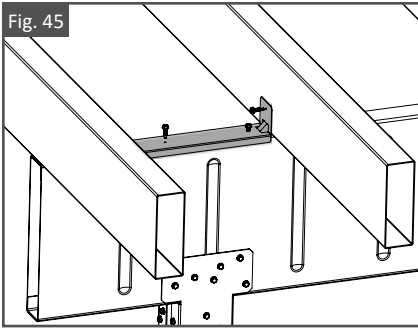

Connection 6A: End Joist To Beam & S-Ledger (Flush Mount - Alternative to Connection 5A)

1. Confirm both ends of the Beam and S-Ledger are in Line. As shown in Fig. 48. Adjust if needed.
2. Attach F-50 Brackets to the outside edges of the Beam with Evolution Self-drilling Screws. As shown in Fig. 49. The notched side of the F-50 Bracket is designed to line up flush with the edge of the Beam.
3. Reference End Joist to S-Ledger mounting steps on page 22, connection 5A: 2 & 3.
4. Using Evolution Self-drilling Screws, fasten End Joists onto F-50 Brackets on Beam Cap. As shown in Fig. 50.

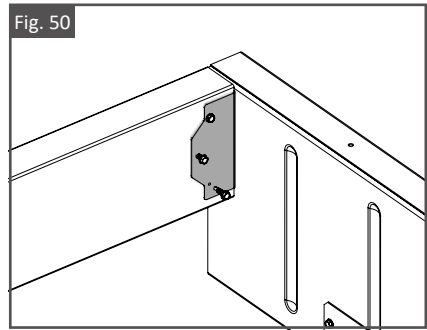
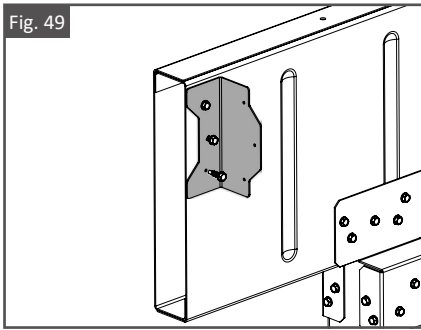
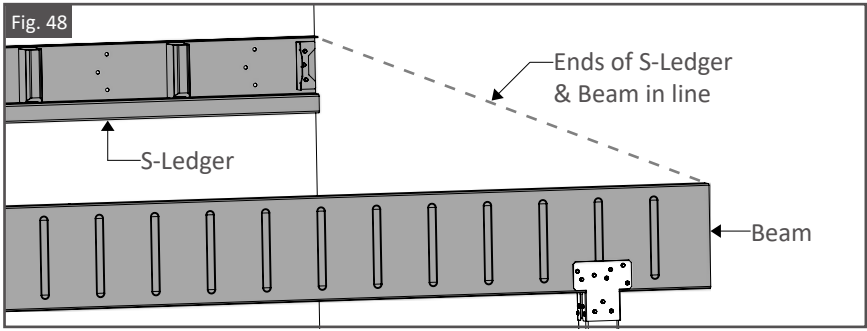

Connection 6B: Joist To Beam & S-Ledger Continued (Flush Mount - Alternative to Connection 5B)

1. Determine required on center spacing between Joists. Reference on center spacing of Ledger Brackets.
2. Once on center spacing is determined, measure and mark desired on center spacing onto top face of Beam. As shown in Fig. 51.
3. Position Single Hanger Brackets centered on previously marked on center markings then fasten the brackets onto the Beam using Evolution Self-drilling Screws. As shown in Fig. 52.
4. Measure opening between S-Ledger and Single Hanger Bracket. Cut joists to length, if required. Reference pages 11 - 13 for cutting and panting instructions.
5. Reference Joist to Ledger Bracket mounting steps on page 24, connection 5B: 1 & 2.
6. Slide Joists into the Single Hanger Brackets.

- Using Evolution Self-Drilling Screws, fasten additional joists onto Single Hanger Brackets on Beam. As shown in Fig. 53.

Note:

- Standard spacing between joists:** 12" [305mm] on center or 16" [406mm] on center.

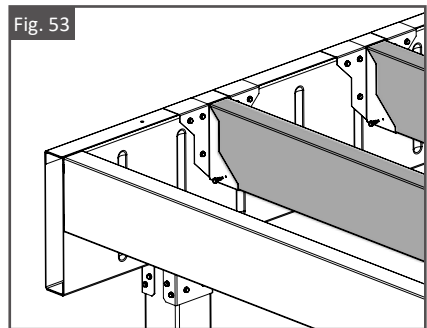
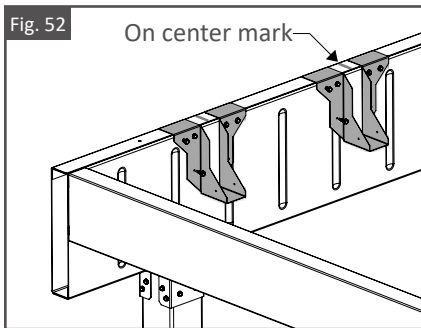
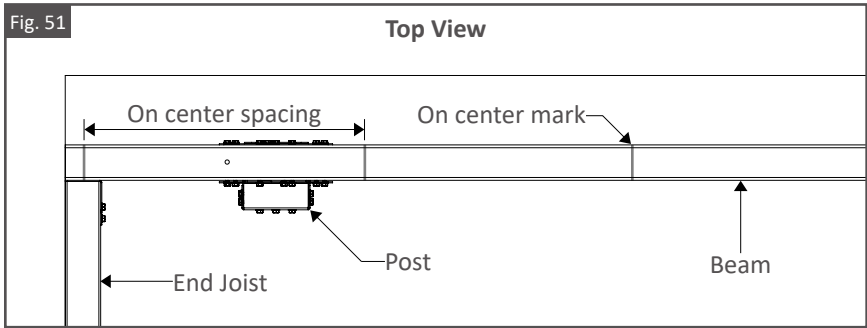

Connection 7A: Evolution Strap To Joist

- Ground Level Decks:** Place 12" [305mm] or 16" [406mm] O.C. Evolution Strap on the topside of the Joist. As shown in Fig. 54. No fasteners are required when installing Strap on the top-side.
- Elevated Decks:** Place 12" [305mm] or 16" [406mm] O.C. Evolution Strap on the underside of the Joist. As shown in Fig. 55. Fasten strap to joists using Evolution Self-drilling Screws. As shown in Fig. 56.

Note:

- For Joist Spans greater than 8' [2438mm], blocking is required mid-span at every bay.

- **Evolution Strap** mounted to underside of joists is the preferred method for installation and should be used anytime there's access to the bottom of the deck.
- The larger diameter holes in the strap are to allow water to escape when it's installed on the underside of the joist.
- The Evolution Strap is 4' [1219mm] long. The 12" [305mm] O.C. version and will cover 4 Joists. The 16" [406mm] O.C. version and will cover 3 Joists.

Fig. 54

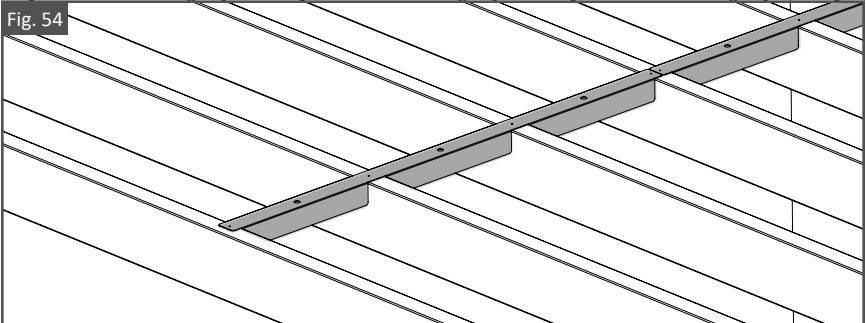

Fig. 55

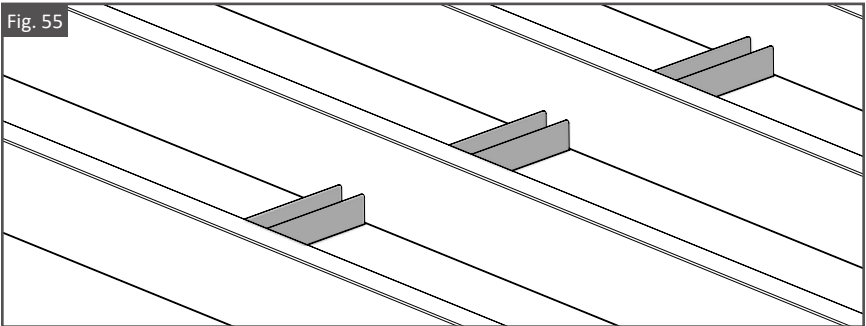
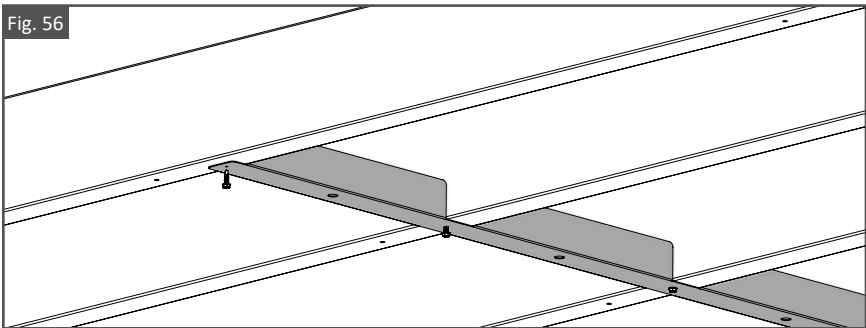

Fig. 56



Connection 7B: Non-Standard Spacing at Mid-Span & General Blocking

1. Place two F-50 Brackets opposite of each other in desired position on Joists. As shown in Fig. 57. Be sure brackets are in line to allow for easy install of Blocking.
2. Using Evolution Self-drilling Screws, fasten the two F-50 Brackets onto joists.
3. Cut Joists, to be used as standard blocking, to the desired length. Reference pages 11 - 13 for cutting and panting instructions.
4. Using Evolution Self-drilling Screws, fasten cut Joist to two F-50 Brackets. As shown in Fig. 58.

Note:

- This method can be used for blocking in cases when there's non-standard spacing and the pre-engineered mid-span strap and beam blocking cannot be used.
- This method can be used in general applications when extra blocking is needed for more structure and support. This can be the case when railing or stairs are being installed, extra framing for deck board picture framing, etc.

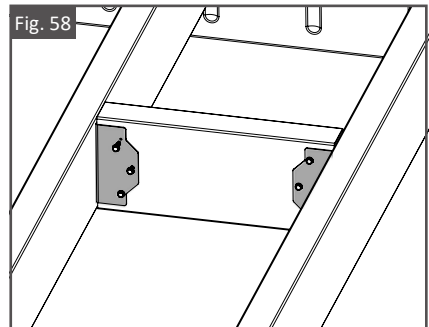
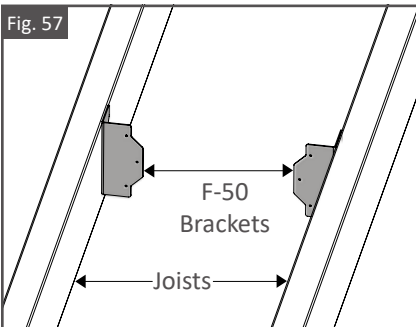

Connection 8A: Pre-Punched U-Rim Joist To Joists

1. Mount pre-punched U-Rim Joist onto exposed ends of Joists. As shown in Fig. 59. Be sure pre-punched slots on U-Rim Joist cover Joist holes with tabs exposed.
2. Using Evolution Self-drilling Screws, fasten U-Rim Joist onto Joists. As shown in Fig. 60.

- Using Evolution Self-drilling Screws, fasten ends of U-Rim joist onto top face of End Joists. As shown in Fig. 61. Be sure edge of the Pre-punched U-Rim is flush with outside edge of the Joist.

Note:

- The pre-punched U-Rim Joist should **ONLY** be used when fascia will mount on the Rim of the deck. Not having fascia will result in exposed openings that may be unsightly.
- The pre-punched U-Rim Joist is designed to provide a completely flat surface for fascia mounting.

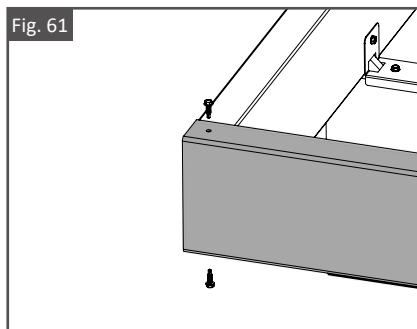
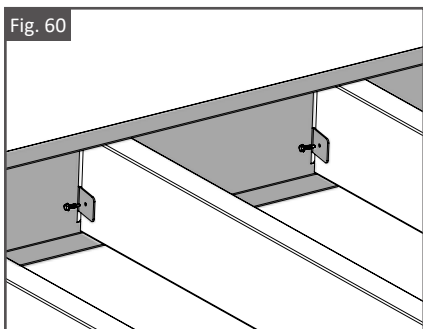
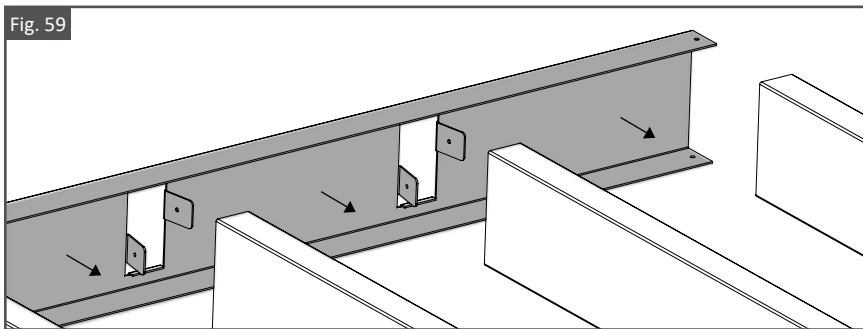

Connection 8B: Blank U-Rim Joist To Joists

- Mount Blank U-Rim Joist onto exposed ends of Joists. As shown in Fig. 62.
- Using Evolution Self-drilling Screws, fasten on top and bottom faces of the Blank U-Rim Joist. As shown in Fig. 63. Be sure edge of the Blank U-Rim Joist is flush with outside edge of the End Joist.

Note:

- The Blank U-Rim Joist is used anytime there's non-standard Joist spacing or no fascia will be used on the rim of the deck.

Fig. 62

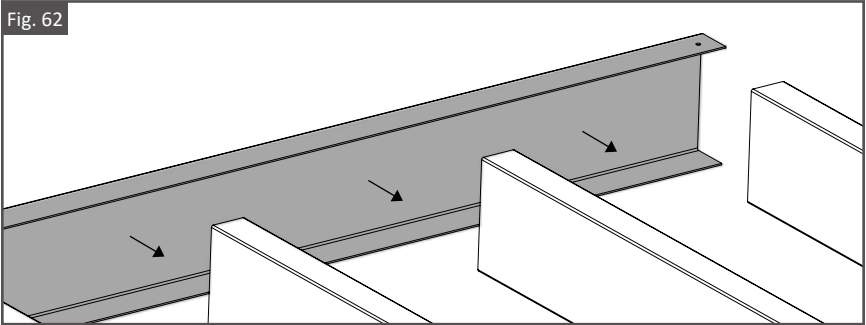
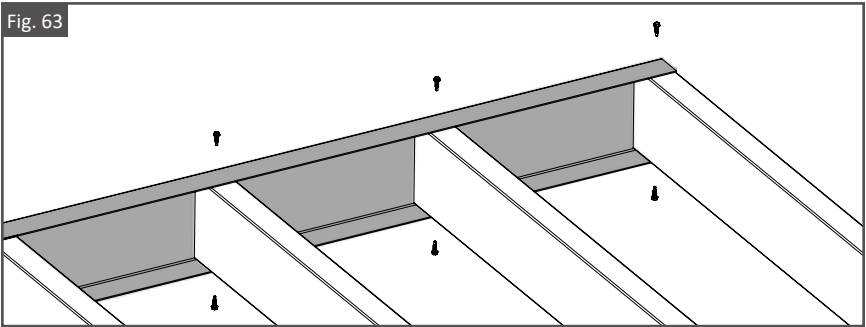

Fig. 63



Connection 8C: Curved U-Rim Joist To Joists

1. Insert Rim Joist Brackets in exposed ends of Joists. As shown in Fig. 64.
2. Using Evolution Self-Drilling Screws, fasten Rim Joist Brackets onto Joists. As shown in Fig. 65. **It is required for a screw to be applied onto each sides of a Joist.**
3. Bend the Curved U-Rim Joist by hand and fit it to the angle of the mounted Rim Joist Brackets. As shown in Fig. 66. Be sure edge of the Curved U-Rim is flush with outside edge of the end Joist.
4. On external face of the Curved U-Rim, determine and mark the position of the Rim Joist Bracket tab.
5. Use locking pliers to bend the Rim Joist Bracket tab to the desired angle.

- Using Evolution Self-drilling Screws, fasten the Curved U-Rim onto the Rim Joist Bracket tab. As shown in Fig. 67.
- Using Evolution Self-drilling Screws, fasten ends of the Curved U-Rim Joist onto top and bottom face of End Joists. Reference Fig. 61 on page 30 of Pre-punched U-Rim Joist installation (Connection 8A).

Note:

- The Curved Rim Joist is used anytime there's a radius on the rim of a deck.
- There's no need to angle cut the joists at the rim when you use the Curved U-Rim Joist and the Rim Joist Bracket.

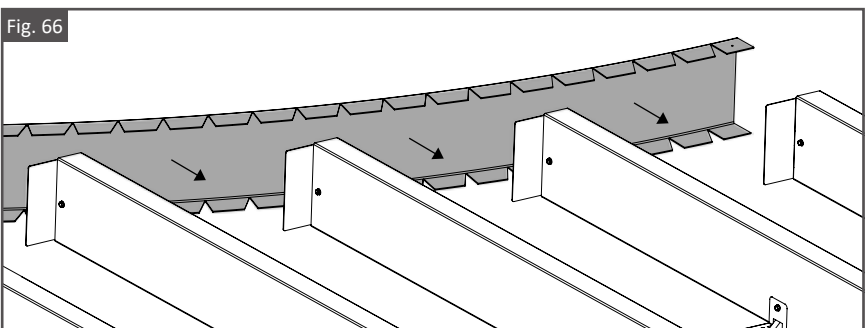
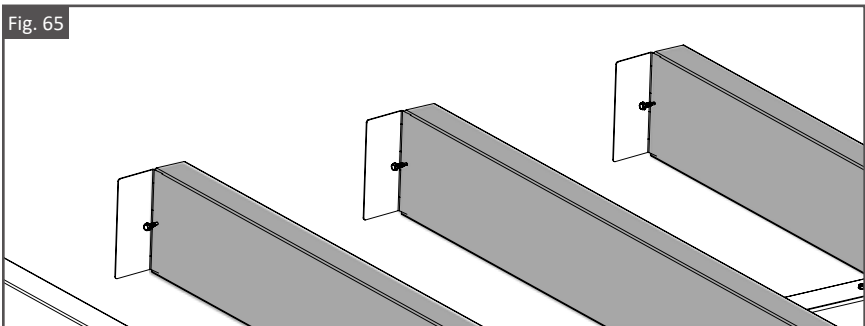
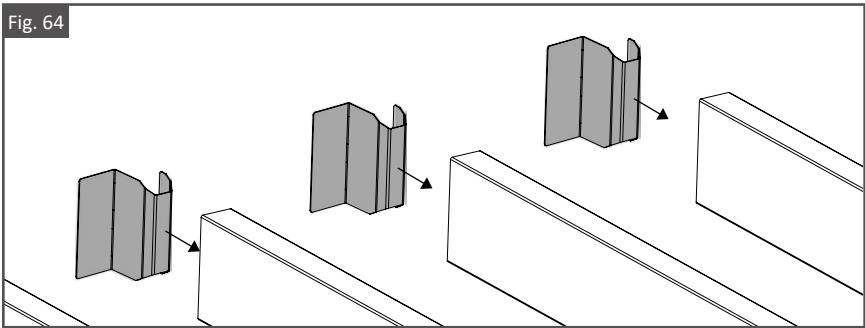
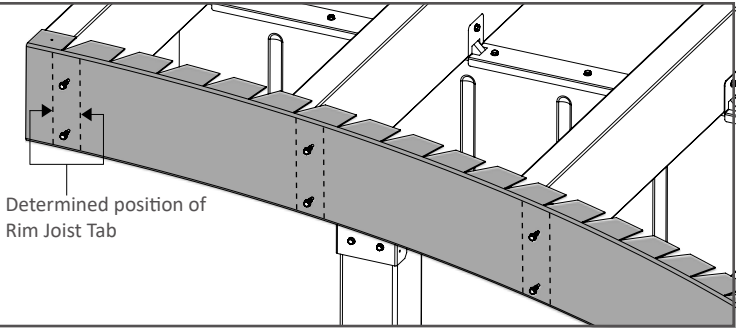

Fig. 67



Connection 8D: Joist As Rim Joist (Alternative to Connections 8A & 8B)

1. Mount F-50 Brackets in desired position onto exposed ends of frame joists.
2. Using Evolution Self-drilling Screws, fasten the F-50 Bracket onto the End Joist. As shown in Fig. 68. Be sure back face of bracket is flush with open edge of Joist.
3. Insert Ledger Brackets into the ends of all the Joists. As shown in Fig. 69.
4. Using Evolution Self-drilling Screws, fasten Ledger Brackets onto inside face of Joists.
5. Mount Joist onto exposed ends of Joists. As shown in Fig. 70.
6. Using Evolution Self-drilling Screws, fasten Ledger Brackets & F-50 Brackets onto Joist. As shown in Fig. 71. Be sure edge of the Joist is flush with outside edge of the End Joist.
7. Install Joist Caps to exposed ends of Joist. Reference Joist Cap installation steps on page 35.

Note:

- The “Joist as Rim Joist” option can be used with or without fascia and leave a completely flat surface on the rim.

Fig. 68

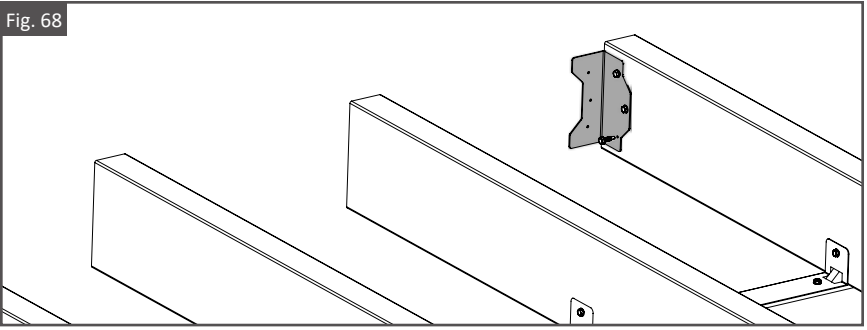

Fig. 69

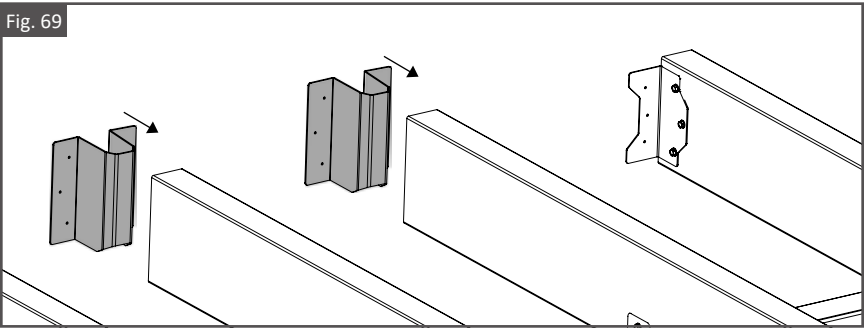

Fig. 70

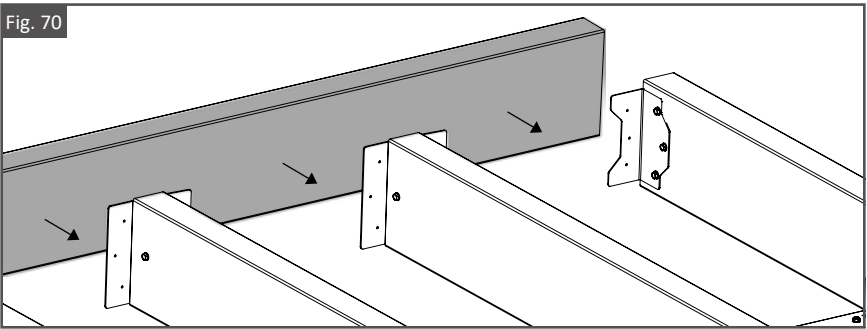
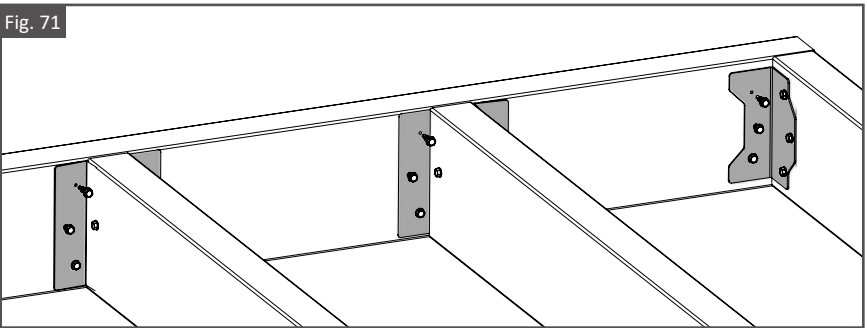

Fig. 71



Connection 9: Joist & Beam Cap

1. Position the Joist or Beam Cap on end of Joist or Beam. As shown in Fig. 72.
2. Using Evolution self-drilling screws, fasten Joist or Beam Cap onto Joist or Beam. As shown in Fig. 73.

Note:

- Use the Evolution Joist or Beam Caps to cover the open ends of the joists or beams.

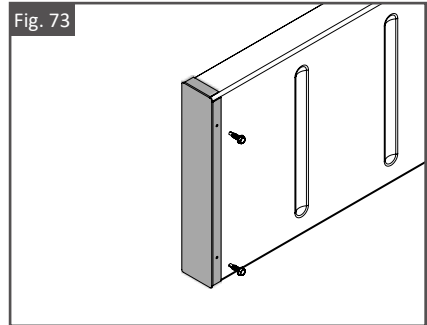
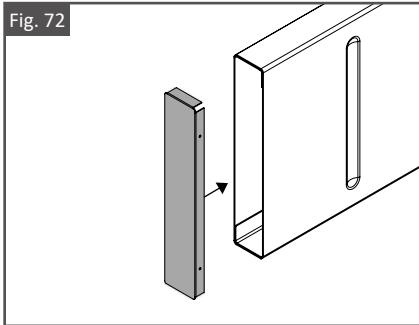

Connection 10A: Beam Splice Over 5.5" Post

Note:

- The below instructions apply to 5.5" Post for single beam (shown) and double beam installations.
1. Attach the single beam clamshell bracket and flush bracket to the top of the post using Evolution self-drilling screws, 7x to install each bracket (Fig. 74).

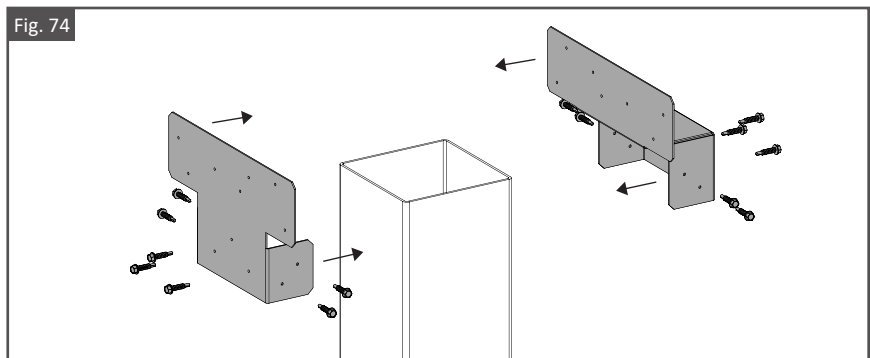

2. Position the post cap beam support aligning its screw holes with the corresponding holes on the flush bracket (Fig.75). Do not fasten until beam is installed (Fig. 76).

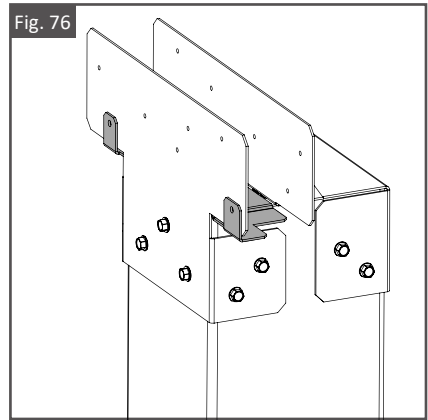
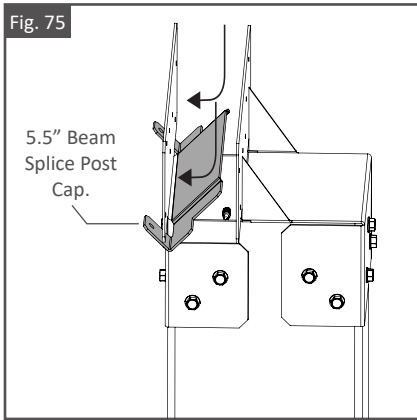

3. Lower the two beams you are splicing over the post. At least 1.5" [38.1mm] of the beam end must be over the post. The gap between the ends of the beams should be no more than 1/8" [3.18mm] (Fig. 77).

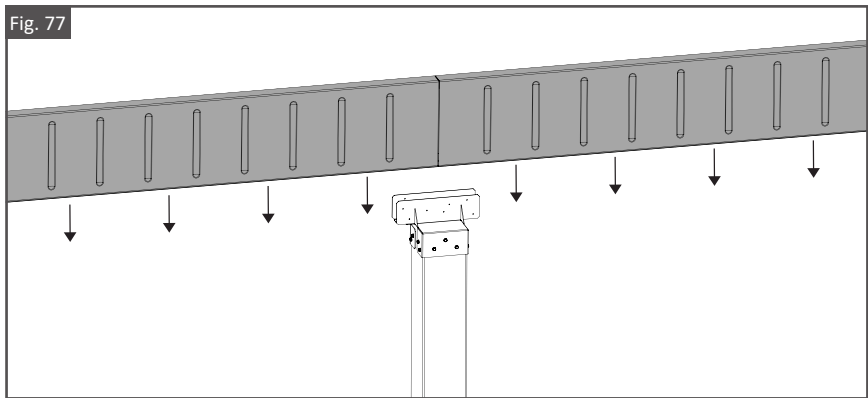

4. Secure beam using Evolution self-drilling screws, 7x per side through the clamshell bracket and the flush bracket with positioned post cap beam support (Fig. 78). Next, attach 8" [203mm] straps to each side of the beam on center, securing them with 2x 3/8" [9.53mm] grade 8 galvanized and coated through bolts (sold separately). See fig. 79 for finished assembly.

Fig. 78

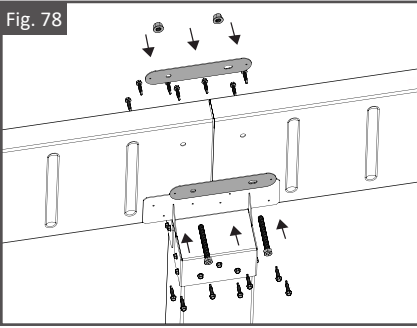
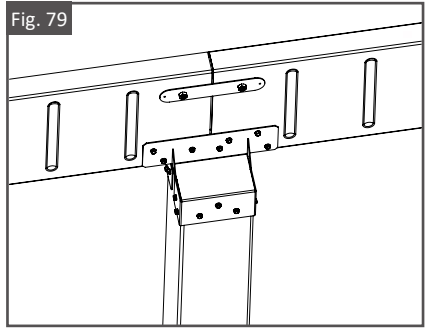

Fig. 79



Connection 10B: Beam Splice Over 3.5" Post

Note:

- The below instructions apply to 3.5" Post for single beam and double beam (shown) installations.
1. Attach the double beam clamshell bracket and flush bracket to the top of the post using Evolution self-drilling screws, 7x to install each bracket (Fig. 80).

Fig. 80

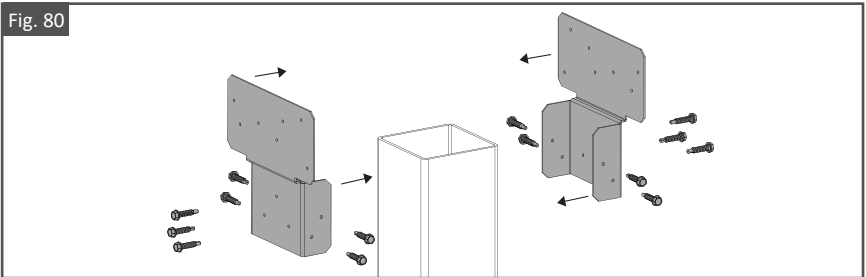

2. Position the beam splice post caps (sold separately item #183191601) beam side by side over the clamshell brackets and post (Fig.81 and Fig. 82).

Fig. 81

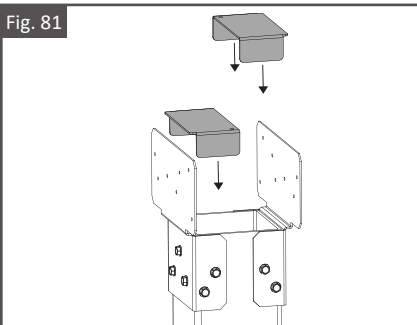
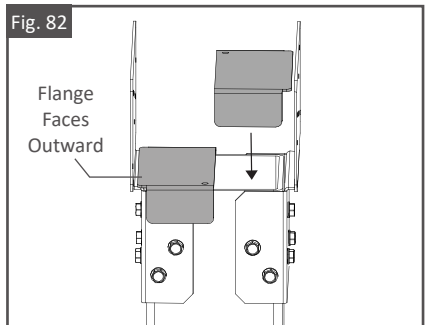
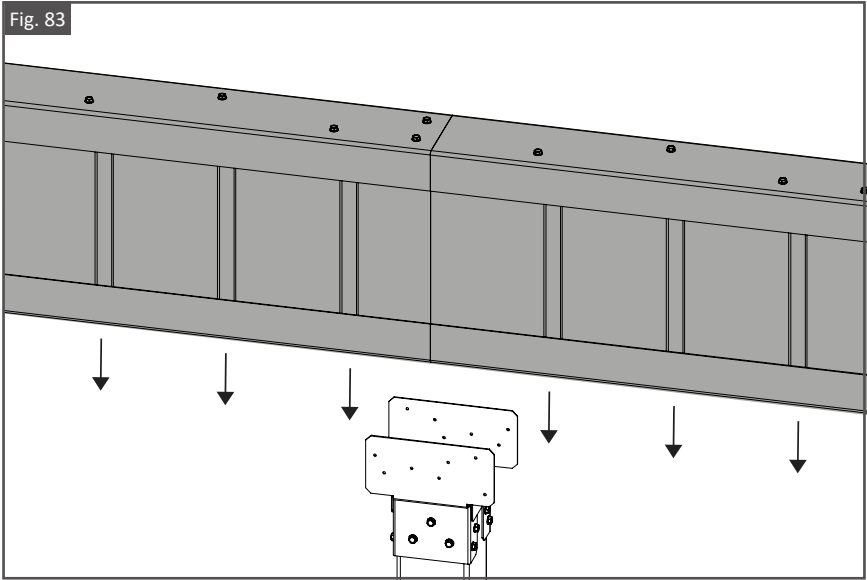

Fig. 82



3. Lower the two double (shown) or single beams you are splicing over the post. At least 1.5" [38.1mm] of the beam end must be over the post. The gap between the ends of the beams should be no more than 1/8" [3.18mm](Fig. 83).



4. Secure beam using Evolution self-drilling screws, 7x per side through the clamshell bracket and the flush bracket with positioned post cap beam support (Fig. 84). Next, attach straps to each side of the beam on center, securing them with 2x 3/8" [9.53mm] grade 8 galvanized and coated through bolts (sold separately). See Fig. 85 for finished assembly.

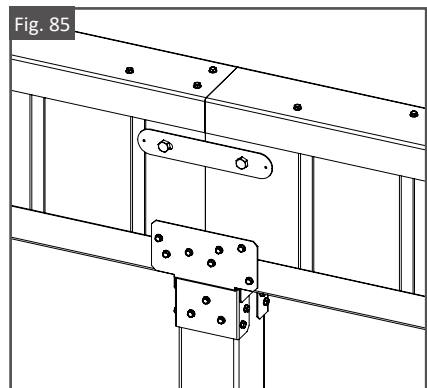
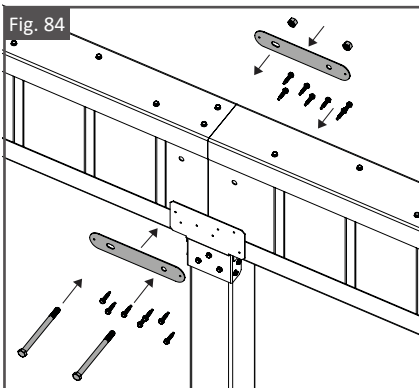

Connection 13A: Tile Tray Installation and Spacing 12" or 16" OC

Note:

- Tile Trays have a 2" [50mm] Max spacing, with the ability to fully nest to a flush condition. (Fig. 88)

1. Lay tile tray with the open channel and tabs seated on 12" [305mm] or 16" [406mm] on-center joists. (Fig. 86 and Fig. 87)

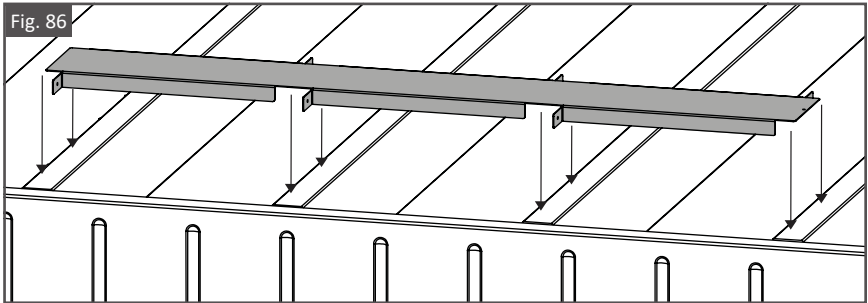

2. Once tile trays are seated on joists, space them as desired. The vertical tabs on each tray are designed to nest into other trays for spacing flexibility. Use a maximum 2" [50mm] spacing to help avoid undesirable deflection. (Fig. 88)

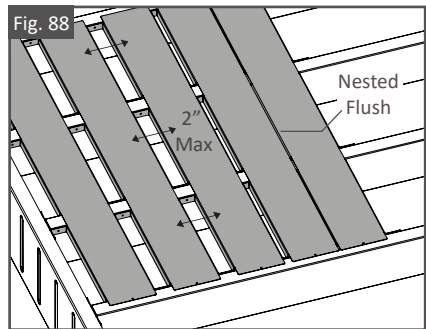
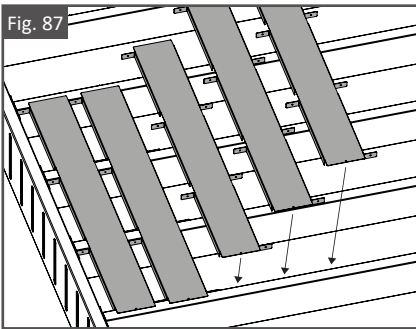

3. Fasten tile tray(s) to joists with Evolution self-drilling screws as shown (Fig. 89).

Note:

- If access to underside of frame is limited, fasten each tray sequentially before laying and spacing each additional one. The gap (Fig. 90) ensures fasteners will not obstruct additional trays from being spaced as desired.

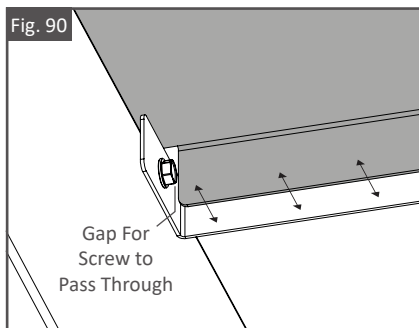
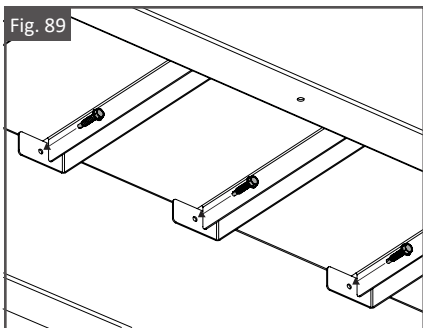

Connection 13B: Tile Tray Flush Against Beam (or similar)

Note:

- Approach may vary for each framing design.
1. If laying a tile tray flush against a beam (or similar framing element), cut off or bend tabs 90 degrees on the side(s) that will face the beam. (Fig. 91)
 2. After bending or cutting tabs, lay tile tray over joists flush against the beam (or similar framing element) and fasten with Evolution self-drilling screws through remaining tabs. (Fig. 92)

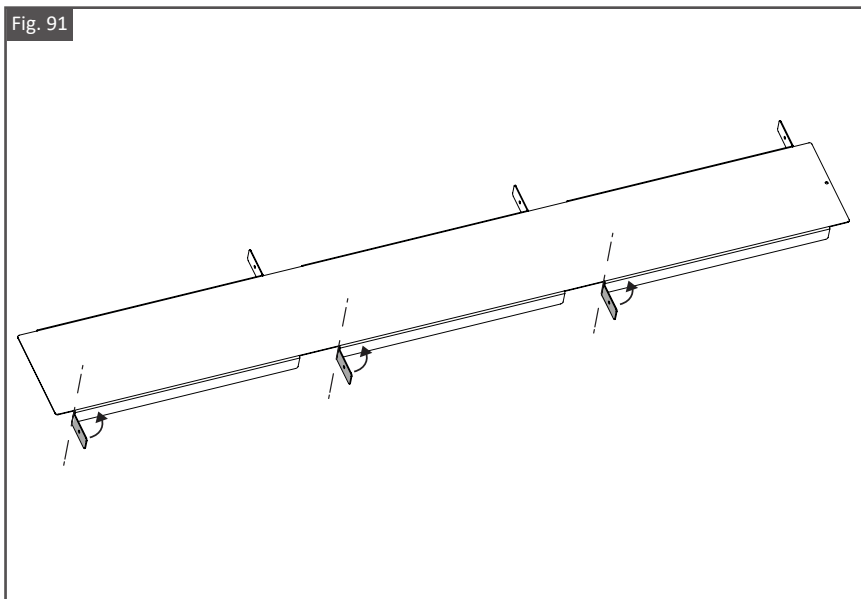
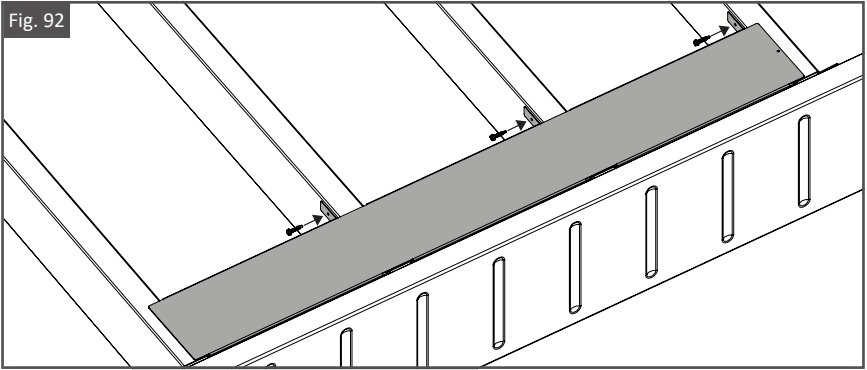

Fig. 92



Connection 13C: Tile Tray Notched Around Post

Note:

- Approach may vary for each framing design.
1. Measure X and Y from post in frame layout (Fig. 93) and transfer those dimensions on the tile tray, accounting for the flange the sits on the joist or beam. (Fig. 94)

Fig. 93

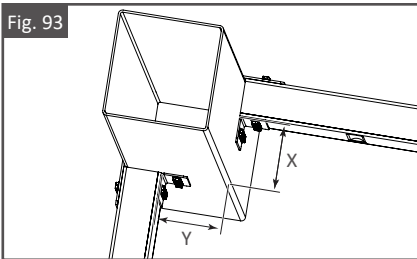
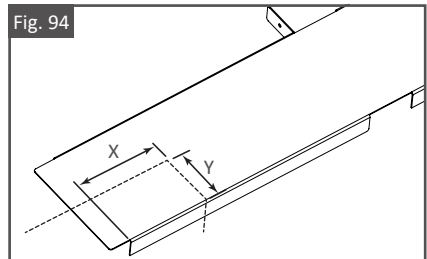

Fig. 94



2. Cut or bend tabs as needed (connection 13B). Then, cut notch A on the top surface, and notch B on vertical surface (Fig. 95). Bend as shown (Fig. 96)

Fig. 95

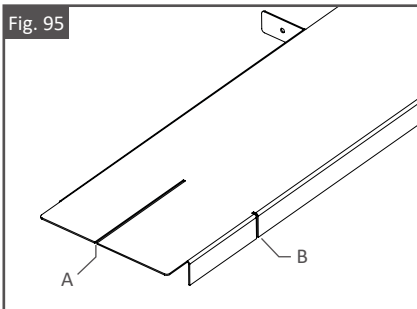
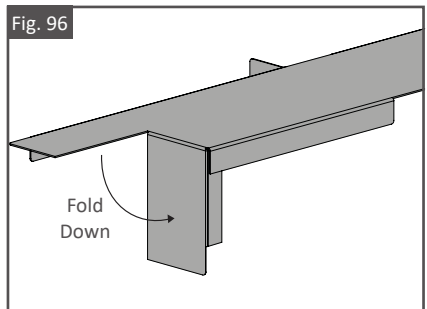
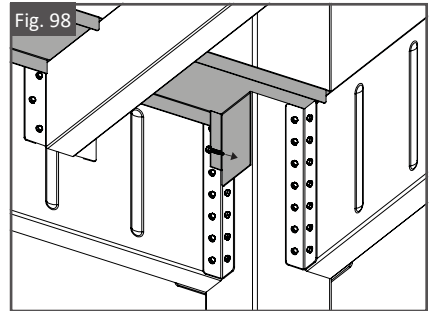
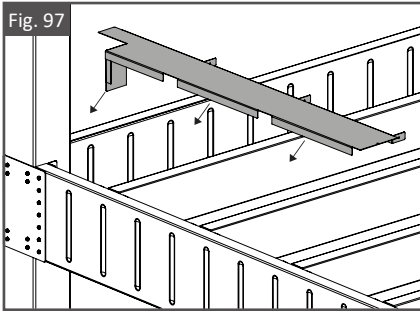

Fig. 96



3. Lay your notched tile tray around post on 12" [305mm] or 16" [406mm] on-center joists. (Fig. 97)
4. Fasten notched tile tray with Evolution self-drilling screws through remaining tabs to joists, with at least one screw through the folded section as shown (Fig. 98).



Connection 13D: Tile Tray over Single Span 12" or 16" OC

1. Measure and cut tile tray over channel on-center (Fig. 99) to create a single span tile tray. (Fig. 100)

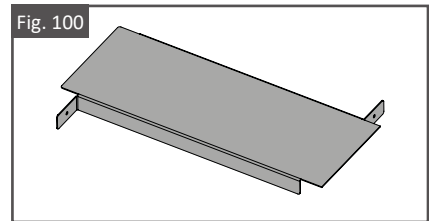
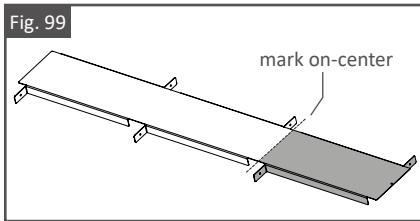

2. Lay cut tile tray on 12" [305mm] or 16" [406mm] on-center joists. (Fig. 101) Fasten with Evolution self-drilling screws through remaining tabs to the joists. (Fig. 102)

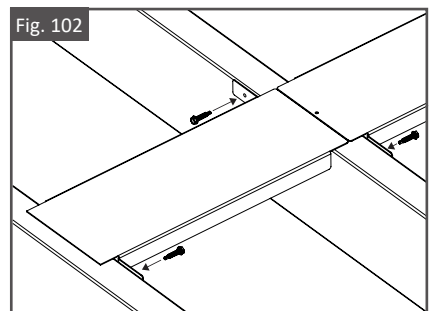
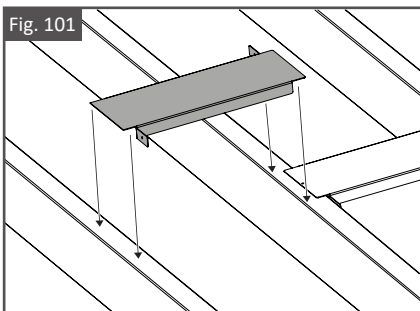

Connection 13E: Tile Tray Over Non-Nominal Joist Spacing

Note:

- The following are recommended steps for installing tile trays over joist spans less than 16" or 12" on-center. Approach may vary for each framing design.
1. Measure joist spans on-center (not the gap between the joists), then translate to tile tray, and cut. (Fig. 103)
 2. Mark and cut notches inside bend of vertical faces on either side of tile tray 1 1/4" [32mm], then bend new tabs outward 90 degrees. (Fig. 104) Remove one tab if it impedes nesting with another tile tray.

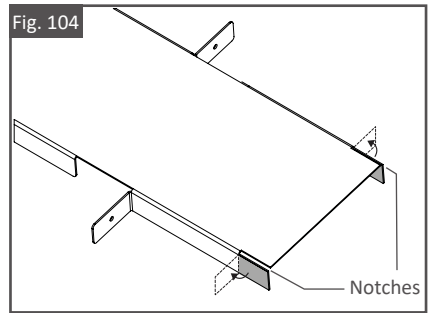
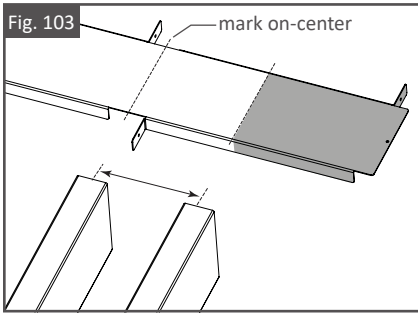

3. Lay custom width tile tray over your joists (Fig. 105) and fasten with Evolution self-drilling screws through remaining tabs to joists. (Fig. 106)

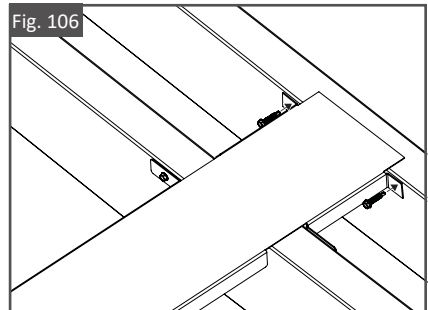
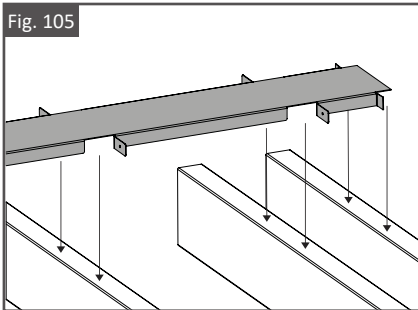

Connection 14: E22 Beam to Mid-Post Bracket Line

Notes:

- E22 Bracket can be used for single and double-beam to mid-post line connections.
 - Lateral bracing to be used in seismic categories D, E, F. In seismic categories A, B, C, lateral bracing may be omitted in lieu of (2) Simpson DTT2Z's to host structure at each deck diaphragm.
1. Measure and mark 2" [50mm] in from open end of beam, position the edge of E22 bracket on that mark. Position supporting L bracket on opposite side of beam, lining it's edge flush with open end of the beam. (Fig. 107)
 2. Clamp and brace as desired, then fasten with Evolution self-drilling screws, 7x on each side as shown. (Fig. 108)

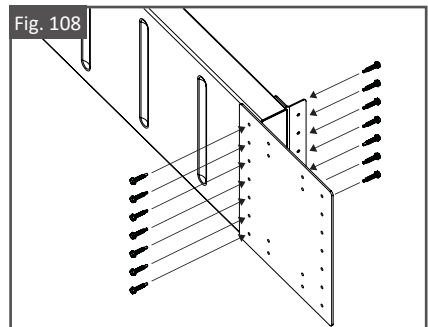
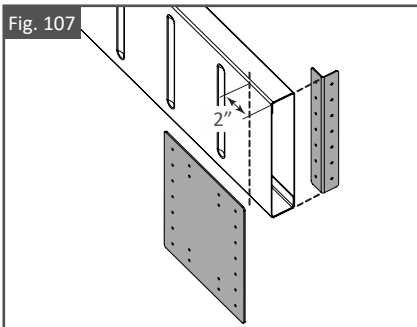

3. Position beam with attached brackets on post as desired height and ensure beam is level and square. (Fig. 109)
4. Clamp and brace, then fasten with Evolution self-drilling screws, 8x for E22 Bracket, 7x for L bracket. (Fig. 110)

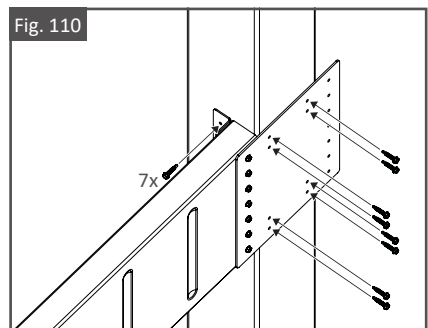
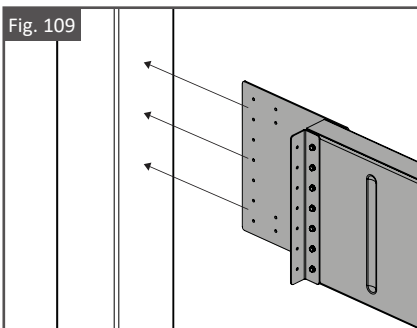

5. Repeat steps 1 and 2 for the L support bracket on the second beam, then position it level, square and in line with the other installed beam. (Fig. 111)
6. Clamp and brace as desired, then fasten with Evolution self-drilling screws, 7x on each side as shown. (Fig. 112)

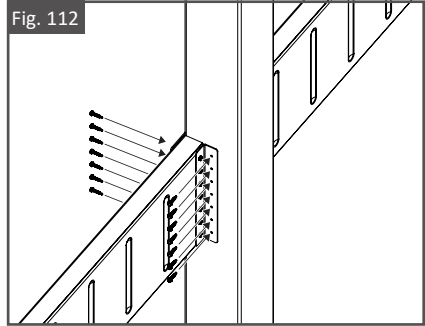
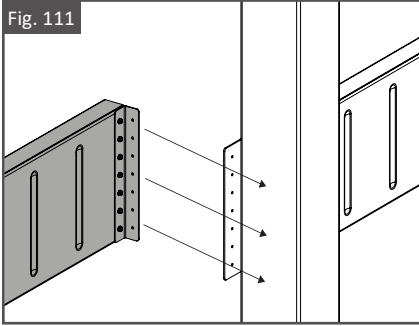

Notes:

- See figure 113 below for finished assembly.
- Lateral bracing to be used in seismic categories D, E, F. Reference Connection 17.

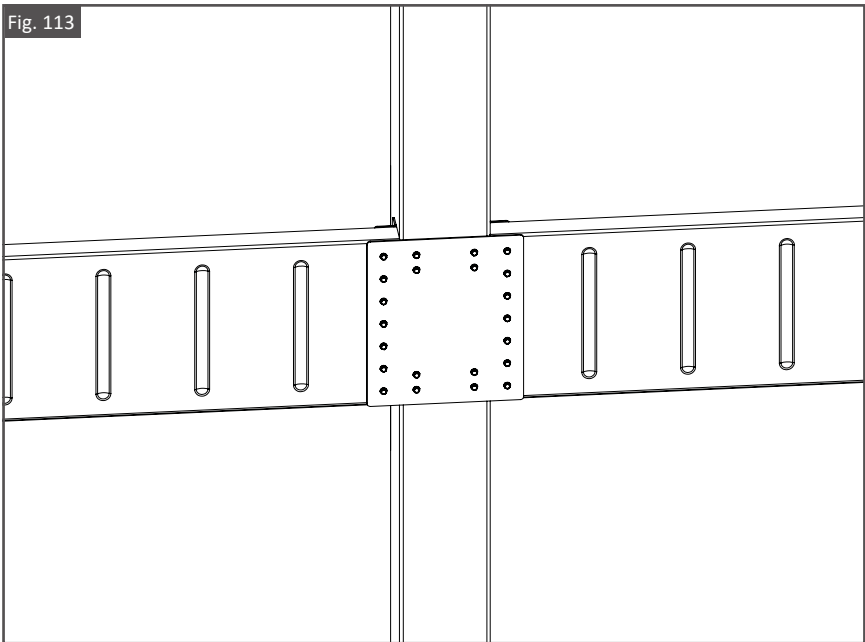

Connection 15: E15 Beam to Mid-Post Bracket End/Corner

Notes:

- E15 Bracket can be used for single and double-beam to mid-post end and corner connections.
- Lateral bracing to be used in seismic categories D, E, F. In seismic categories A, B, C, lateral bracing may be omitted in lieu of (2) Simpson DTT2Z's to host structure at each deck diaphragm.

1. Measure and mark 2" [50mm] in from open end of beam, position the edge of E15 bracket on that mark. Position supporting L bracket on opposite side of beam, lining it's edge flush with open end of the beam. (Fig. 114)
2. Clamp and brace as desired, then fasten with Evolution self-drilling screws, 7x on each side as shown. (Fig. 115)

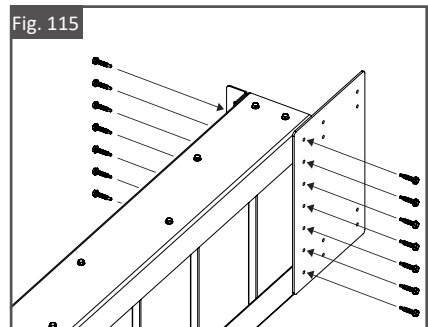
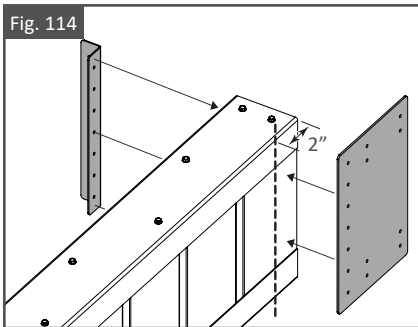

3. Position beam with attached brackets on post as desired height and ensure beam is level and square. (Fig. 116)
4. Clamp and brace, then fasten with Evolution self-drilling screws, 8x for E15 Bracket, 7x for L bracket. (Fig. 117)

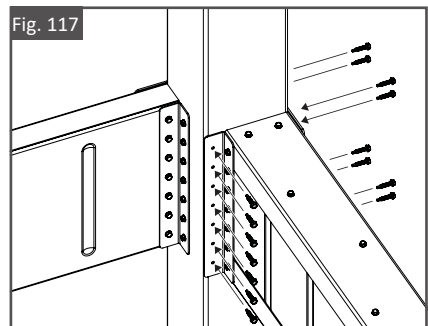
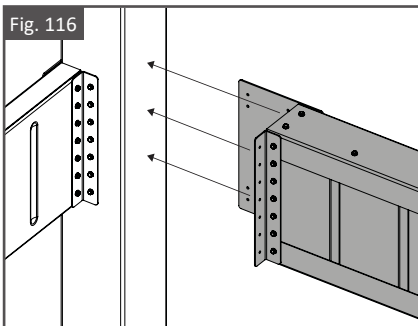

Notes:

- See figure 118 below for finished assembly.
- Lateral bracing to be used in seismic categories D, E, F. Reference Connection 17.

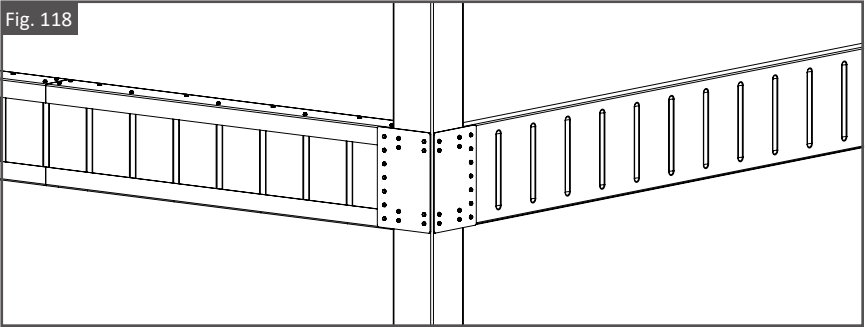

Connection 16: HUCQ Bracket Evolution Beam to Solid Sawn Header, and Evolution Beam to Evolution Beam

Notes:

- Reference [this engineering letter](#) for these connections.
- Supports both single and double-beam connections. (See Figures 119 - 122 for finished assemblies)

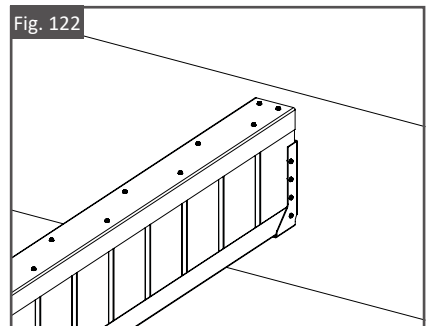
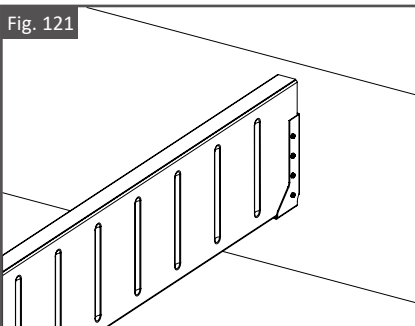
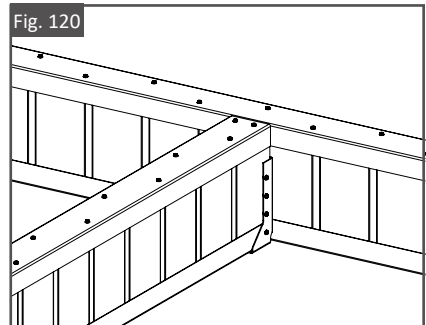
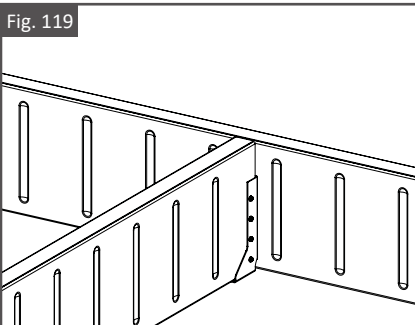

Connection 17: 24in [610mm] Lateral Bracing

1. Measure and mark joist with a 34in [864mm] inner length, making 45-degree outward cuts on both ends. (Fig. 123)
2. Measure as shown and attach F50 brackets to post and beam with Evolution self-drilling screws. (Fig. 124)
3. Attach cut joist to F50 brackets with Evolution Self-drilling screws (Fig. 125).
4. If a corner Post, Repeat steps 1-3 on opposite side.
(See Fig. 126 for finished assembly).

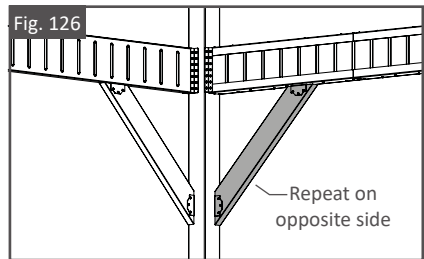
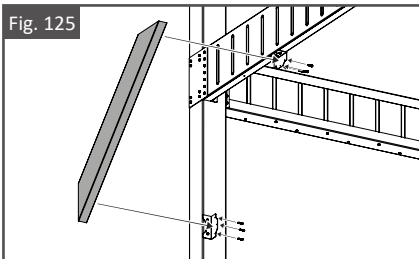
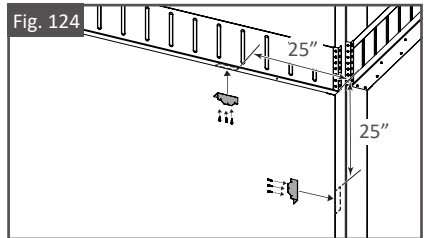
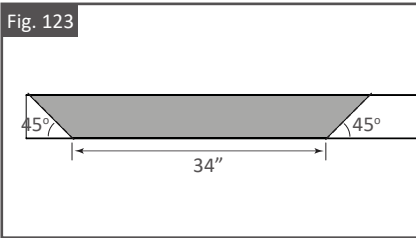

CARE & MAINTENANCE

Care And Maintenance Of Fortress Building Products Powder-Coated Products And Surfaces:

- Immediately after installation of your Fortress Building Products, clean powder-coated products and surfaces with a solution of warm water and non-abrasive, pH neutral detergent solution. Surfaces should be thoroughly rinsed after cleaning to remove all residues. All surfaces should be cleaned using a soft cloth or sponge.
- Ensure construction materials such as concrete, plaster, and paint splashes are removed immediately before they have a chance to dry. Failure to remove these materials may cause damage to the powder-coated surfaces.
- **DO NOT** allow metal shavings and/or chips to get dropped or blown into a pool, hot tub, or any other body of water. Staining could occur if this were to happen.
- The frequency of cleaning depends in part on the standard of appearance and also the requirements to remove deposits that may cause damage to the powder coating after prolonged exposure. Fortress recommends cleaning in three to four monthly intervals.
- **WARNING: Do not use strong solvents such as thinners, or solutions containing chlorinated hydrocarbons, esters, or ketones. Abrasive cleaners or cutting compounds should not be used.**

SPAN CHARTS

Reference <https://bpdirectory.intertek.com/> for span charts. Search for CCRR #0313. It is critical to **NOT** exceed defined allowable maximum spans.

POST TO FRAME CONNECTIONS

Reference <https://fortressbp.com/Documents/install-guide-post-to-evolution-steel-framing-0.pdf> for the Post To Frame Connections.

FRAME INSPECTION CHECKLIST

Reference <https://fortressbp.com/Documents/fbp-new-evolution-framing-form-final-0.pdf> for the frame inspection checklist.

WARRANTY

To obtain and review a copy of the warranty, please go to: <https://Fortressbp.com/warranties>. You can also contact: (844) 909-1999 or write to: Fortress Building Products Warranty, 1720 N 1st St, Garland, TX 75040 to obtain a copy of the warranty.

Note:

- On the fortress website there are two warranties for framing - standard warranty and salt water proximity warranty. Be sure to reference the appropriate warranty.



FORTIFY THE FUTURE.
FortressBP.com | 866.323.4766